

Features

- Supply voltage
 - $V_{CC} = 5\text{ V}$
- Access time: 55 ns
- Program / Erase controller
 - Embedded byte/word program algorithms
- Erase Suspend and Resume modes
- Low power consumption
 - Standby and Automatic Standby
- 100,000 Program/Erase cycles per block
- Electronic signature
 - Manufacturer code: 0x01
 - Top Device codes:
 - M29F200FT: 0x2251
 - M29F400FT: 0x2223
 - M29F800FT: 0x22D6
 - M29F160FT: 0x22D2
 - Bottom Device codes:
 - M29F200FB: 0x2257
 - M29F400FB: 0x22AB
 - M29F800FB: 0x2258
 - M29F160FB: 0x22D8
- RoHS packages available
 - SO44
 - TSOP48
 - TFBGA
- Automotive device grade 3:
 - Temperature: -40 to $125\text{ }^{\circ}\text{C}$
- Automotive device grade 6:
 - Temperature: -40 to $85\text{ }^{\circ}\text{C}$
- Automotive grade certified (AEC-Q100)

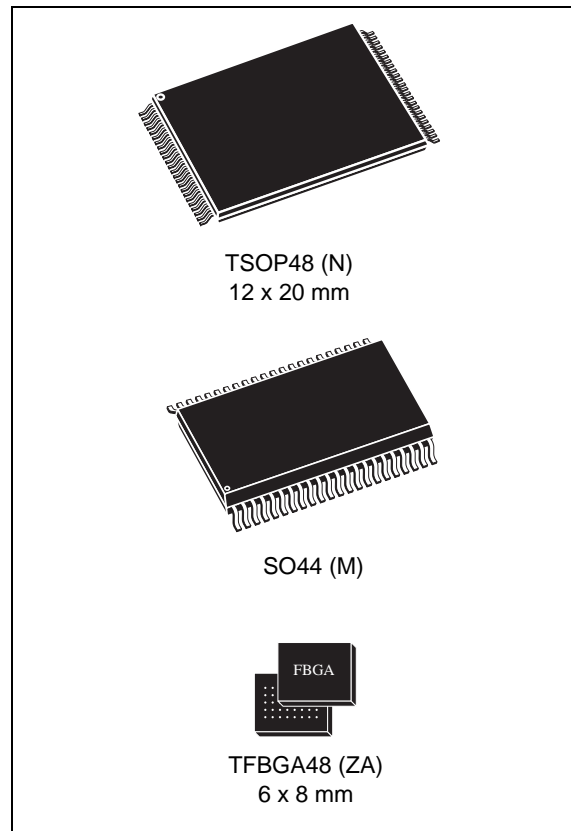

Contents

1	Description	6
2	Signal Descriptions	20
2.1	Address Inputs (A0-A19)	20
2.2	Data Inputs/Outputs (DQ0-DQ7)	20
2.3	Data Inputs/Outputs (DQ8-DQ14)	20
2.4	Data Input/Output or Address Input (DQ15A-1)	20
2.5	Chip Enable	20
2.6	Output Enable	20
2.7	Write Enable	21
2.8	Reset/Block Temporary Unprotect	21
2.9	Ready/Busy Output	21
2.10	Byte/Word Organization Select	21
2.11	V _{CC} Supply Voltage	21
2.12	V _{SS} Ground	22
3	Bus Operations	23
3.1	Bus Read	23
3.2	Bus Write	23
3.3	Output Disable	23
3.4	Standby	23
3.5	Automatic Standby	24
3.6	Special Bus Operations	24
3.7	Electronic Signature	24
3.8	Block Protection and Block Unprotection	24
4	Command Interface	26
4.1	Read/Reset Command	26
4.2	Auto Select Command	26
4.3	Program Command	26
4.4	Unlock Bypass Command	27
4.5	Unlock Bypass Program Command	27

4.6	Unlock Bypass Reset Command	27
4.7	Chip Erase Command	27
4.8	Block Erase Command	28
4.9	Erase Suspend Command	28
4.10	Erase Resume Command	29
4.11	Read CFI Query Command	29
5	Status Register	34
5.1	Data Polling Bit	34
5.2	Toggle Bit	34
5.3	Error Bit	35
5.4	Erase Timer Bit	35
5.5	Alternative Toggle Bit	35
6	Maximum Rating	38
7	DC and AC Parameters	39
8	Package Mechanical	45
9	Part Numbering	48
Appendix A	Block Address Table	49
Appendix B	Common Flash Interface (CFI)	56
Appendix C	Block protection	60
C.1	Programmer Technique	60
C.2	In-System Technique	60
Appendix D	Revision History	66

List of tables

Table 1.	Signal Names	7
Table 2.	Bus Operations, BYTE = V_{IL}	25
Table 3.	Bus Operations, BYTE = V_{IH}	25
Table 4.	Commands, 16-bit mode, BYTE = V_{IH}	30
Table 5.	Commands, 8-bit mode, BYTE = V_{IL}	31
Table 6.	Program/Erase Times and Program/Erase Endurance Cycles, M29F160F	32
Table 7.	Program/Erase Times and Program/Erase Endurance Cycles, M29F800F	32
Table 8.	Program/Erase Times and Program/Erase Endurance Cycles, M29F400F	33
Table 9.	Program/Erase Times and Program/Erase Endurance Cycles, M29F200F	33
Table 10.	Status Register Bits	36
Table 11.	Absolute Maximum Ratings	38
Table 12.	Operating and AC Measurement Conditions	39
Table 13.	Device Capacitance	40
Table 14.	DC Characteristics	40
Table 15.	Read AC Characteristics	41
Table 16.	Write AC Characteristics, Write Enable Controlled	42
Table 17.	Write AC Characteristics, Chip Enable Controlled	43
Table 18.	Reset/Block Temporary Unprotect AC Characteristics	44
Table 19.	TSOP48 – 48 lead Plastic Thin Small Outline, 12 x 20mm, Package Mechanical Data	45
Table 20.	SO44 - 44 lead Plastic Small Outline, 500 mils body width, package mechanical data	46
Table 21.	TFBGA48 6 x 8 mm - 6 x 8 ball array, 0.80 mm pitch, package mechanical data	47
Table 22.	Information scheme	48
Table 23.	Top Boot Block Addresses, M29F160FT	49
Table 24.	Bottom Boot Block Addresses, M29F160FB	50
Table 25.	Top Boot Block Addresses, M29F800FT	51
Table 26.	Bottom Boot Block Addresses, M29F800FB	52
Table 27.	Top Boot Block Addresses, M29F400FT	53
Table 28.	Bottom Boot Block Addresses, M29F400FB	54
Table 29.	Top Boot Block Addresses, M29F200FT	55
Table 30.	Bottom Boot Block Addresses, M29F200FB	55
Table 31.	Query Structure Overview	56
Table 32.	CFI Query Identification String	56
Table 33.	CFI Query System Interface Information	57
Table 34.	Device Geometry Definition	57
Table 35.	Primary Algorithm-Specific Extended Query Table	58
Table 36.	Security Code Area	59
Table 37.	Programmer Technique Bus Operations, BYTE = V_{IH} or V_{IL}	61
Table 38.	Document Revision History	66

List of figures

Figure 1.	Logic Diagram.	7
Figure 2.	TSOP Connections, M29F160F	8
Figure 3.	TSOP Connections, M29F800F	9
Figure 4.	TSOP Connections, M29F400F	10
Figure 5.	TSOP Connections, M29F200F	11
Figure 6.	SO Connections, M29F800	12
Figure 7.	SO Connections, M29F400	13
Figure 8.	SO Connections, M29F200	14
Figure 9.	TFBGA connections (top view through package)	15
Figure 10.	Block Addresses, M29F160 (x8).	16
Figure 11.	Block Addresses, M29F160 (x16).	16
Figure 12.	Block Addresses, M29F800 (x8).	17
Figure 13.	Block Addresses, M29F800 (x16).	17
Figure 14.	Block Addresses, M29F400 (x8).	18
Figure 15.	Block Addresses, M29F400 (x16).	18
Figure 16.	Block Addresses, M29F200 (x8).	19
Figure 17.	Block Addresses, M29F200 (x16).	19
Figure 18.	AC Measurement I/O Waveform.	39
Figure 19.	AC Measurement Load Circuit	39
Figure 20.	Read Mode AC Waveforms	40
Figure 21.	Write AC Waveforms, Write Enable Controlled	41
Figure 22.	Write AC Waveforms, Chip Enable Controlled	42
Figure 23.	Reset/Block Temporary Unprotect AC Waveforms.	43
Figure 24.	TSOP48 – 48 lead Plastic Thin Small Outline, 12 x 20mm, Package Outline, top view.	45
Figure 25.	SO44 – 44 lead plastic small outline, 500 mils body width, package outline	46
Figure 26.	TFBGA48 6 x 8 mm - 6 x 8 ball array, 0.80 mm pitch, package outline	47
Figure 27.	Programmer Equipment Block Protect Flowchart.	62
Figure 28.	Programmer Equipment Chip Unprotect Flowchart	63
Figure 29.	In-System Equipment Block Protect Flowchart.	64
Figure 30.	In-System Equipment Chip Unprotect Flowchart	65

1 Description

The following overview of the Numonyx® Axcell™ M29F 5 V Flash Memory device (M29W160F) refers to the 16-Mbit device. However, the information can also apply to lower densities of the M29F device.

The M29F160F is a 16 Mbit (2 Mbit x8 or 1 Mbit x16) non-volatile memory that can be read, erased and reprogrammed. These operations can be performed using a single low voltage (4.5 to 5.5 V) supply. On power-up the memory defaults to its Read mode where it can be read in the same way as a ROM or EPROM.

The memory is divided into blocks that can be erased independently so it is possible to preserve valid data while old data is erased. Each block can be protected independently to prevent accidental Program or Erase commands from modifying the memory. Program and Erase commands are written to the Command Interface of the memory. An on-chip Program/Erase Controller simplifies the process of programming or erasing the memory by taking care of all of the special operations that are required to update the memory contents.

The end of a program or erase operation can be detected and any error conditions identified. The command set required to control the memory is consistent with JEDEC standards.

The blocks in the memory are asymmetrically arranged, as shown in [Figure 10.: Block Addresses, M29F160 \(x8\)](#) and [Figure 11.: Block Addresses, M29F160 \(x16\)](#). The first or last 64 KBytes have been divided into four additional blocks. The 16 KByte Boot Block can be used for small initialization code to start the microprocessor, the two 8 KByte Parameter Blocks can be used for parameter storage and the remaining 32K is a small Main Block where the application may be stored.

Chip Enable, Output Enable and Write Enable signals control the bus operation of the memory. They allow simple connection to most microprocessors, often without additional logic.

The memory is offered in TSOP48 (12 x 20mm), SO44 , and TFBGA48 (0.8 mm pitch) packages. The memory is supplied with all the bits erased (set to '1').

Figure 1. Logic Diagram

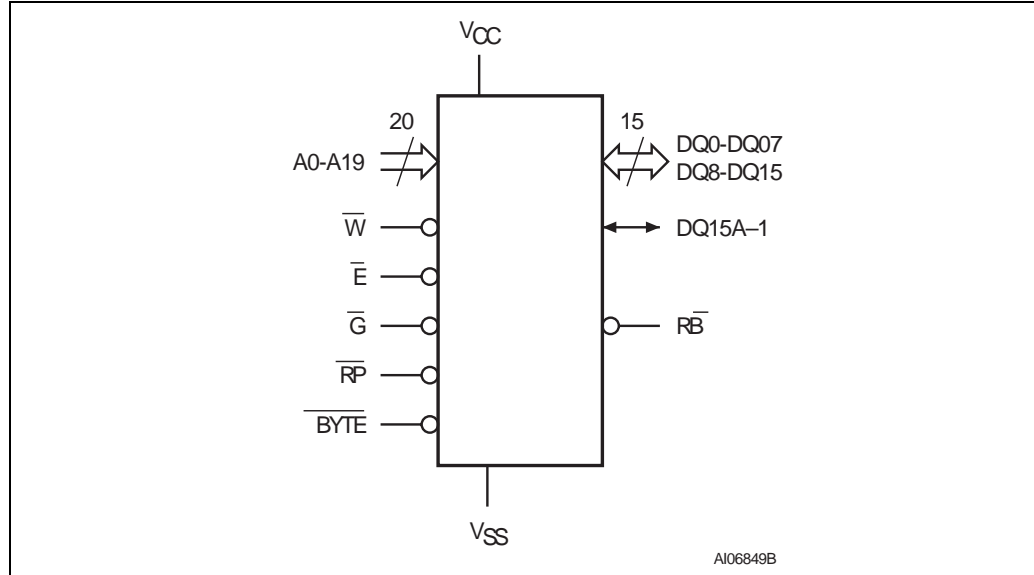

Table 1. Signal Names

A0-A19	Address Inputs
DQ0-DQ7	Data Inputs/Outputs
DQ8-DQ14	Data Inputs/Outputs
DQ15A-1	Data Input/Output or Address Input
\bar{E}	Chip Enable
\bar{G}	Output Enable
\bar{W}	Write Enable
\bar{RP}	Reset/Block Temporary Unprotect
\bar{RB}	Ready/Busy Output
\bar{BYTE}	Byte/Word Organization Select
V_{CC}	Supply Voltage
V_{SS}	Ground
NC	Not Connected Internally

Figure 2. TSOP Connections, M29F160F

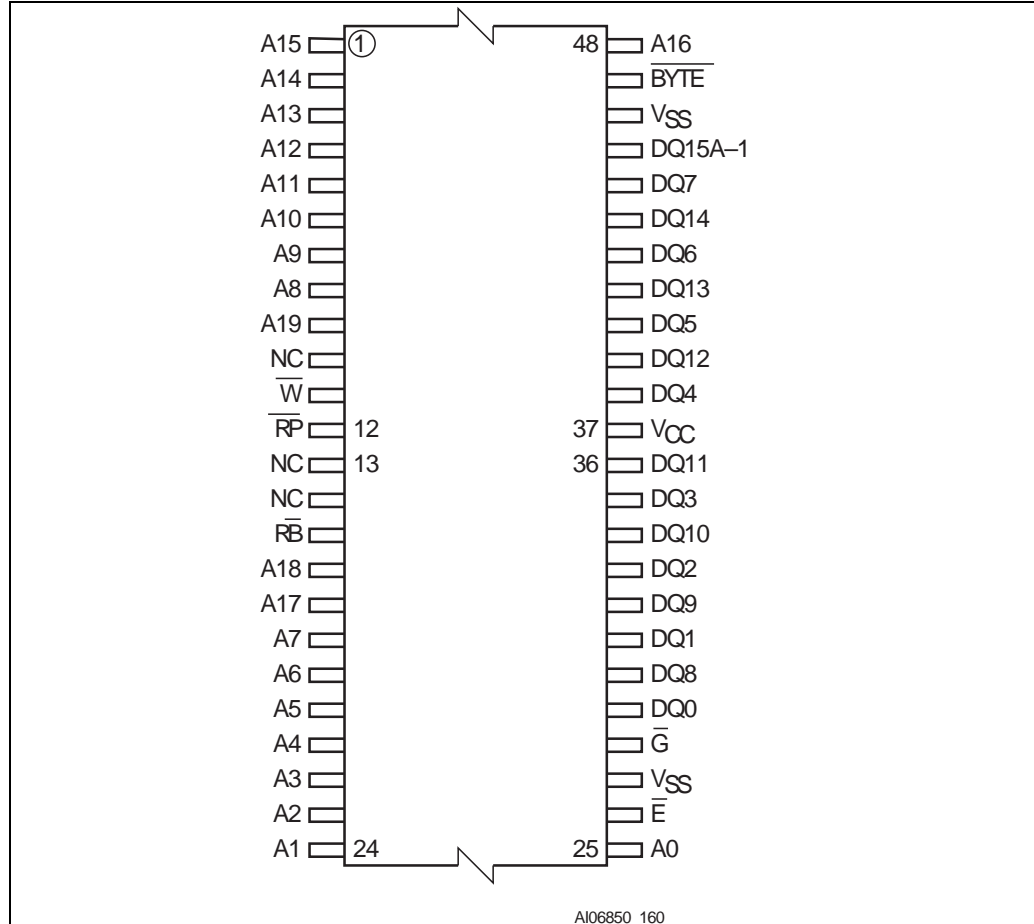

Figure 3. TSOP Connections, M29F800F

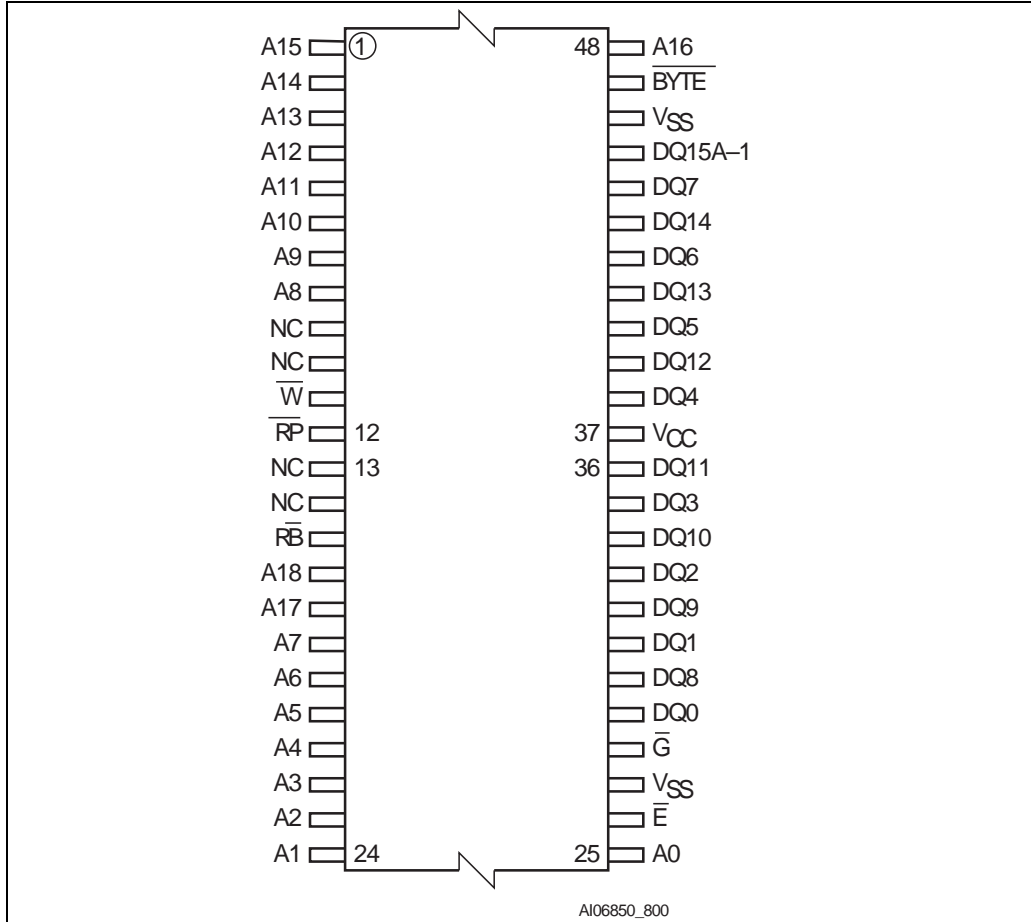

Figure 4. TSOP Connections, M29F400F

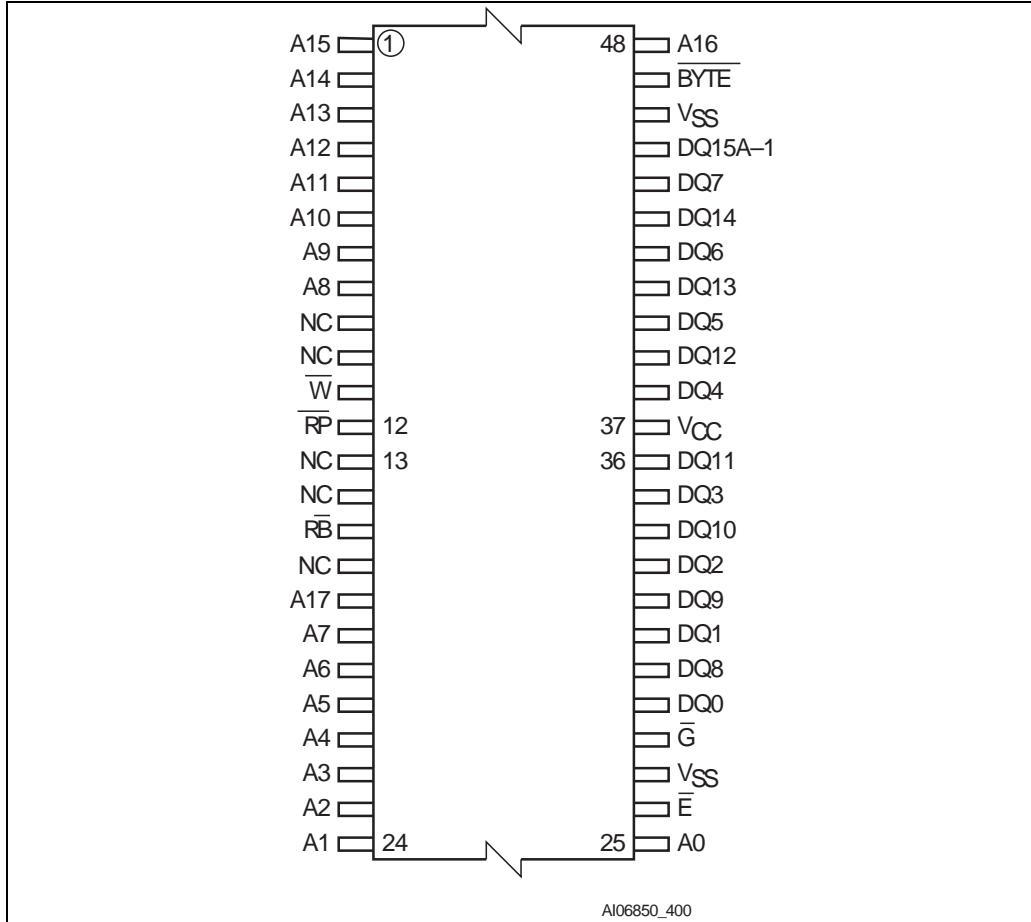

Figure 5. TSOP Connections, M29F200F

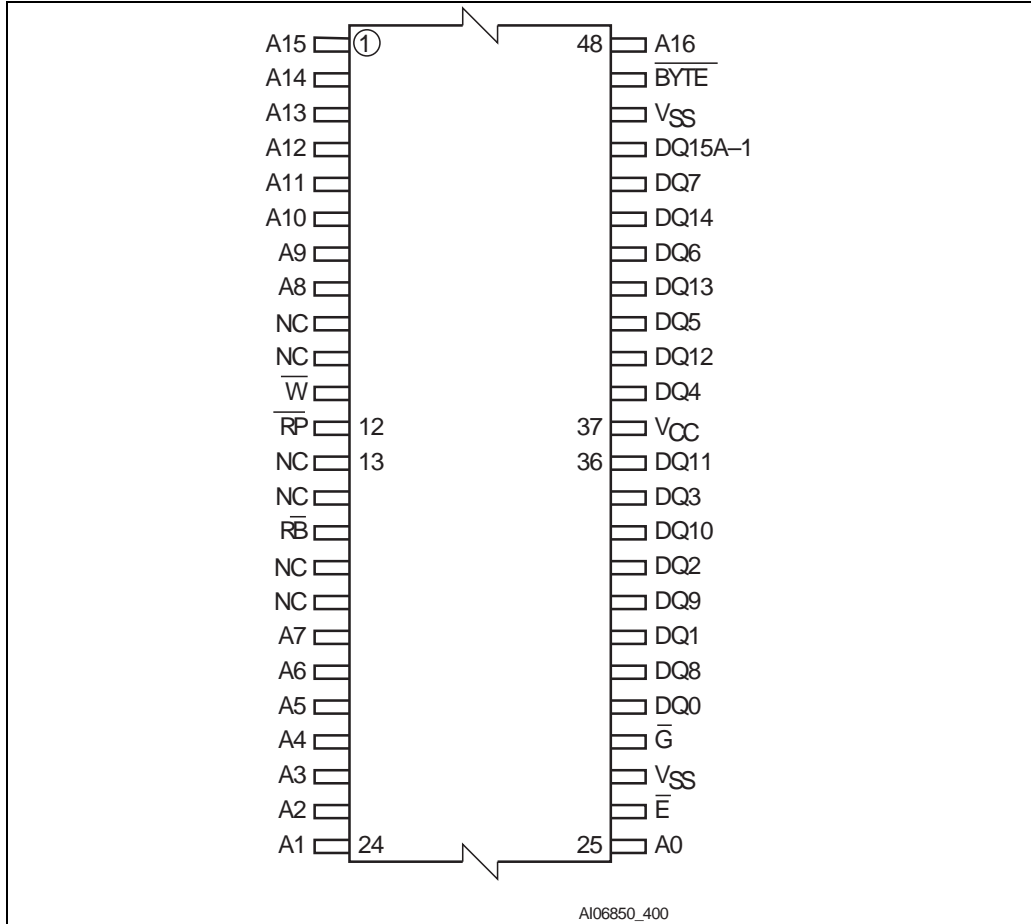

Figure 6. SO Connections, M29F800

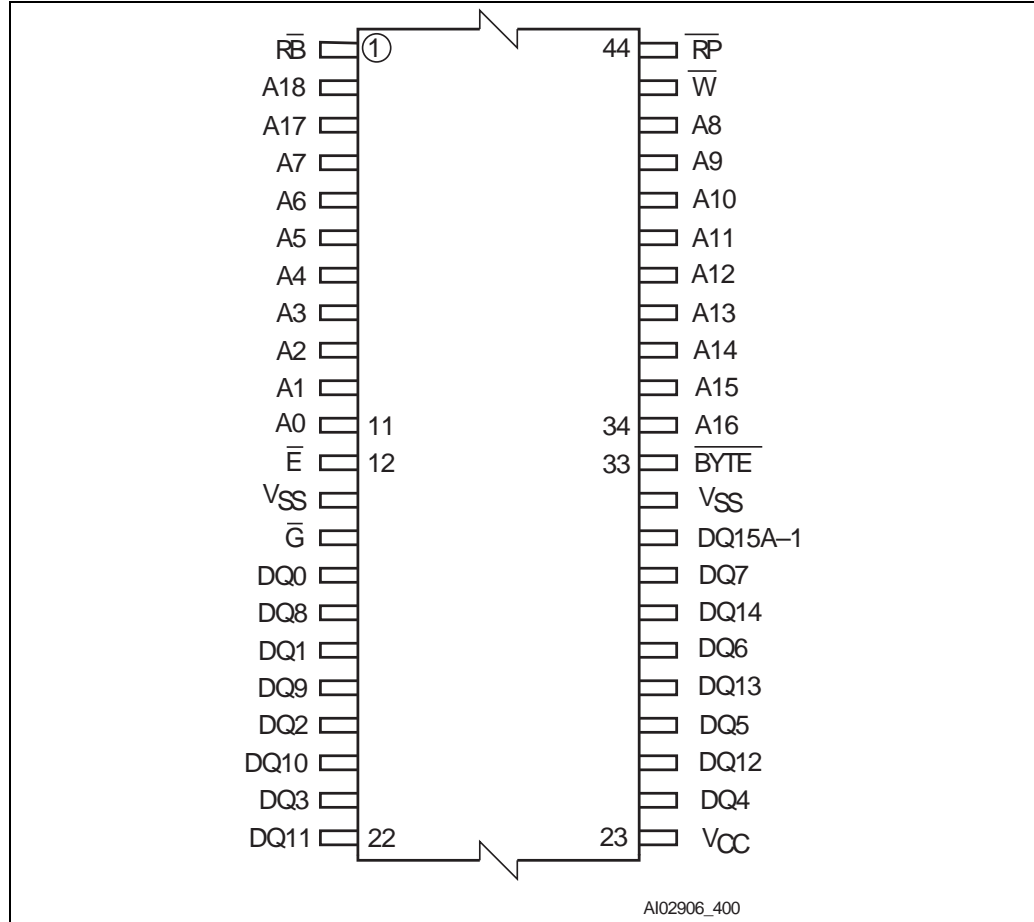

Figure 7. SO Connections, M29F400

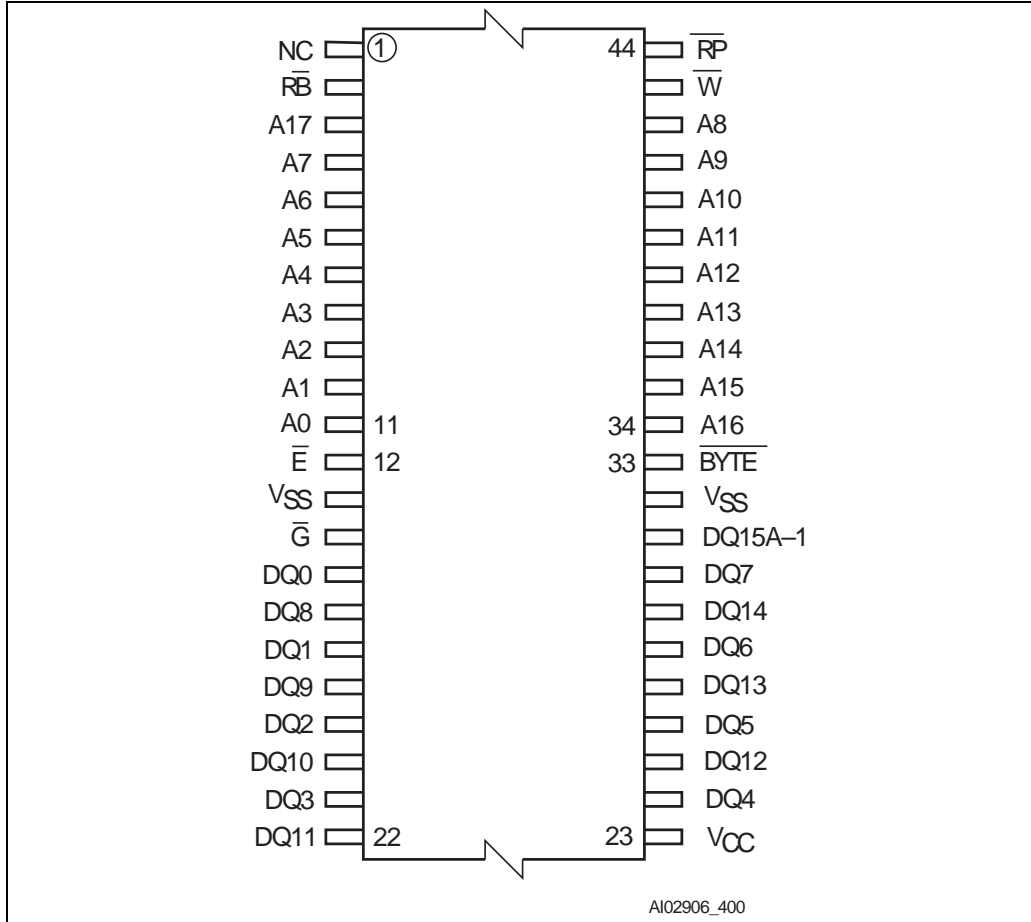

Figure 8. SO Connections, M29F200

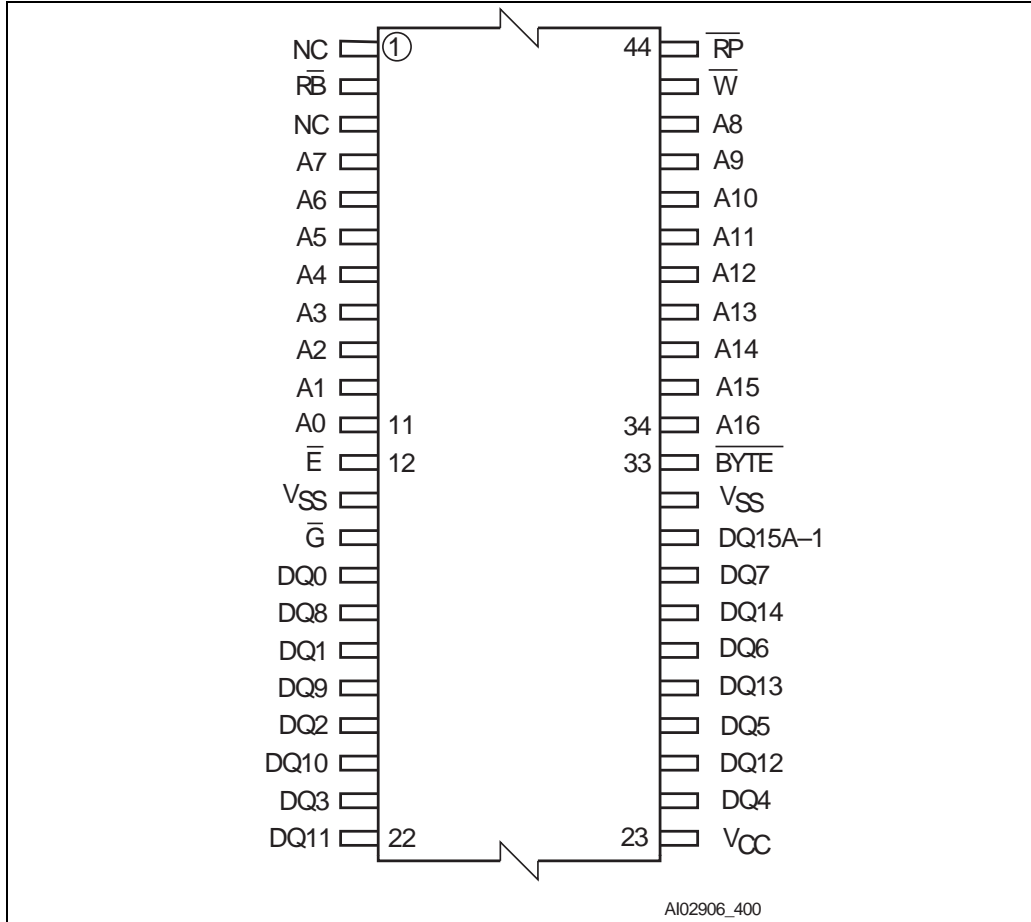
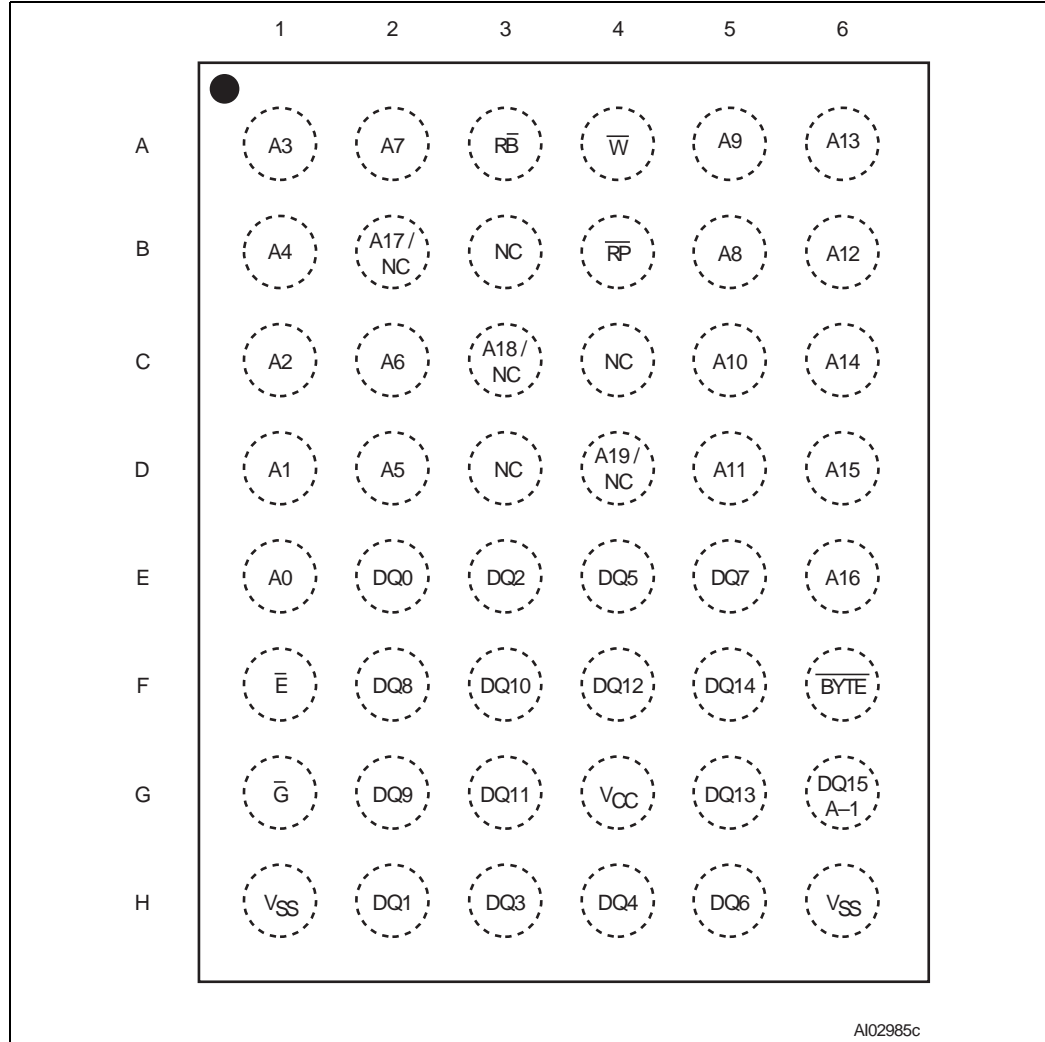
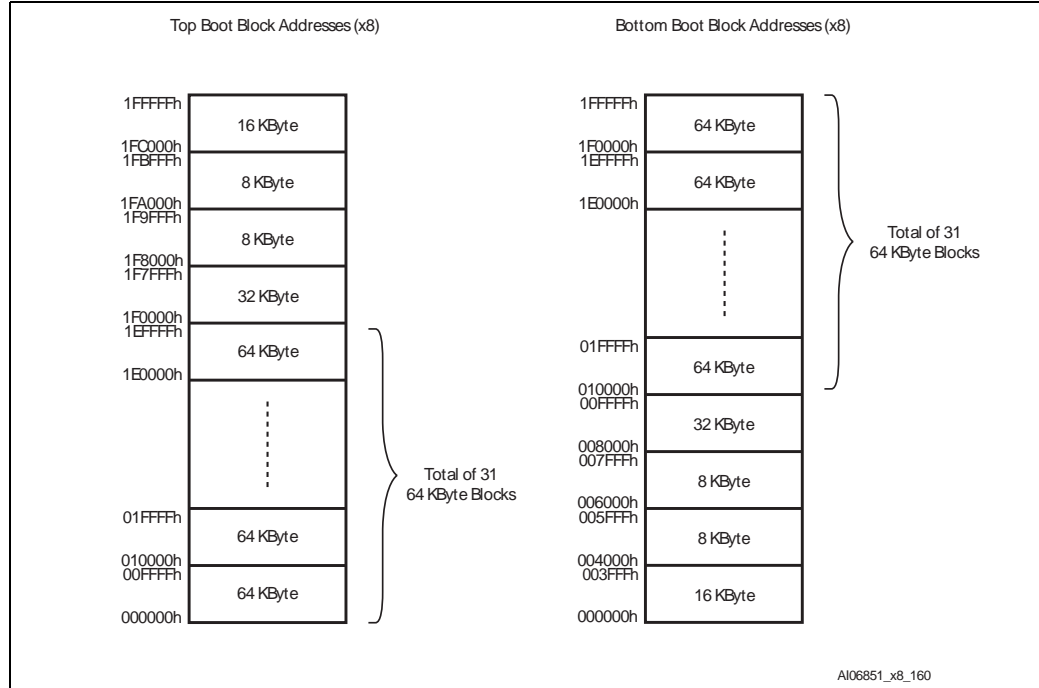

Figure 9. TFBGA connections (top view through package)



1. On the M29F800FT/B, A19 is NC (no connect); on the M29F400FT/B, A19-A18 are NC; on M29F200FT/B, A19-A18-A17 are NC.

Figure 10. Block Addresses, M29F160 (x8)



Also see Appendix [Appendix A: Block Address Table](#) for a full listing of the Block Addresses.

Figure 11. Block Addresses, M29F160 (x16)

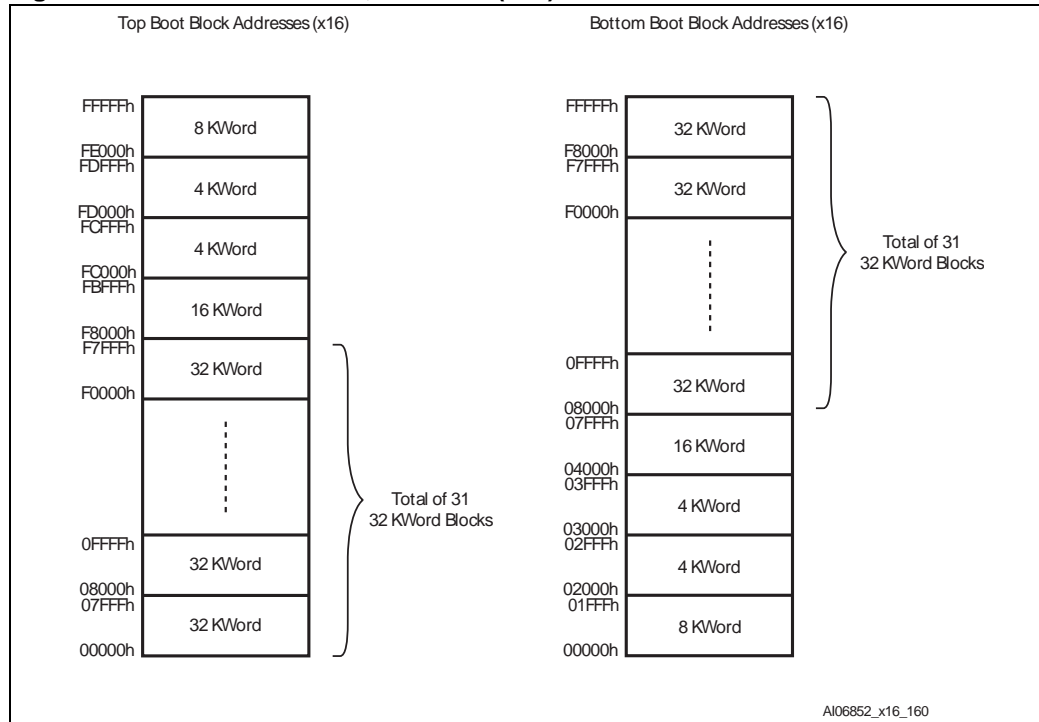

Also see Appendix [Appendix A: Block Address Table](#) for a full listing of the Block Addresses.

Figure 12. Block Addresses, M29F800 (x8)

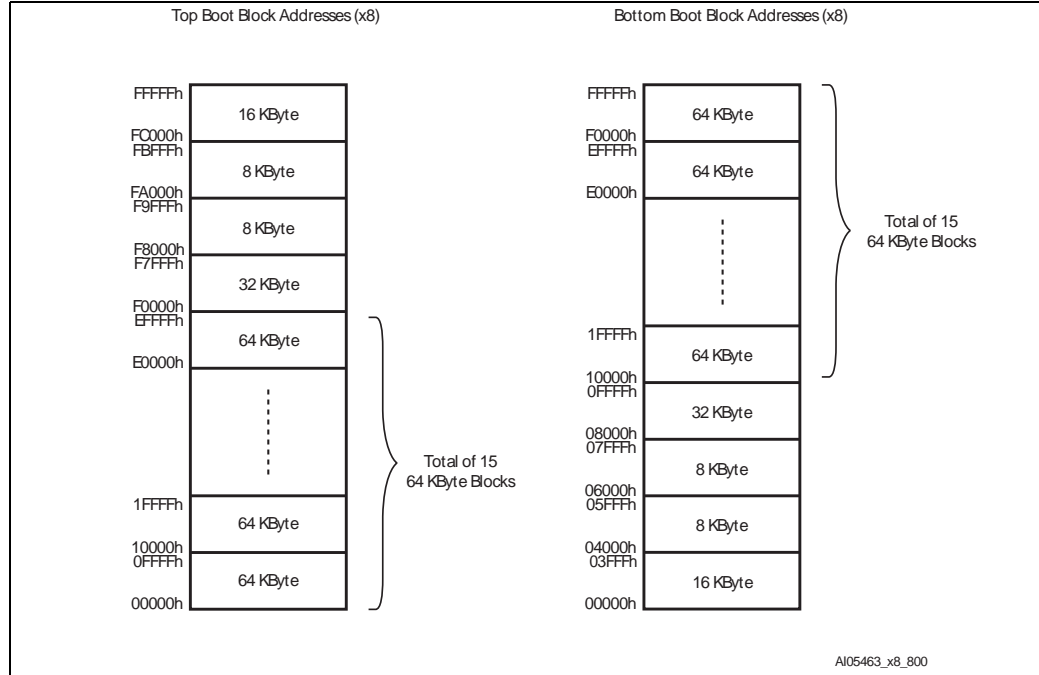

Also see Appendix [Appendix A: Block Address Table](#) for a full listing of the Block Addresses.

Figure 13. Block Addresses, M29F800 (x16)

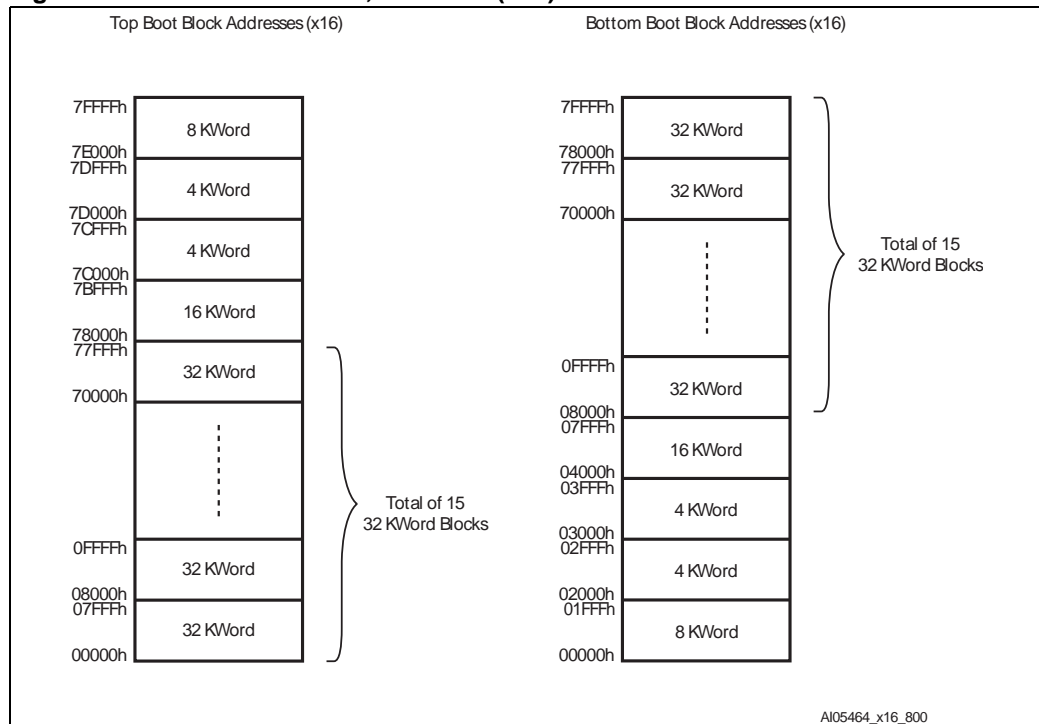

Also see Appendix [Appendix A: Block Address Table](#) for a full listing of the Block Addresses.

Figure 14. Block Addresses, M29F400 (x8)

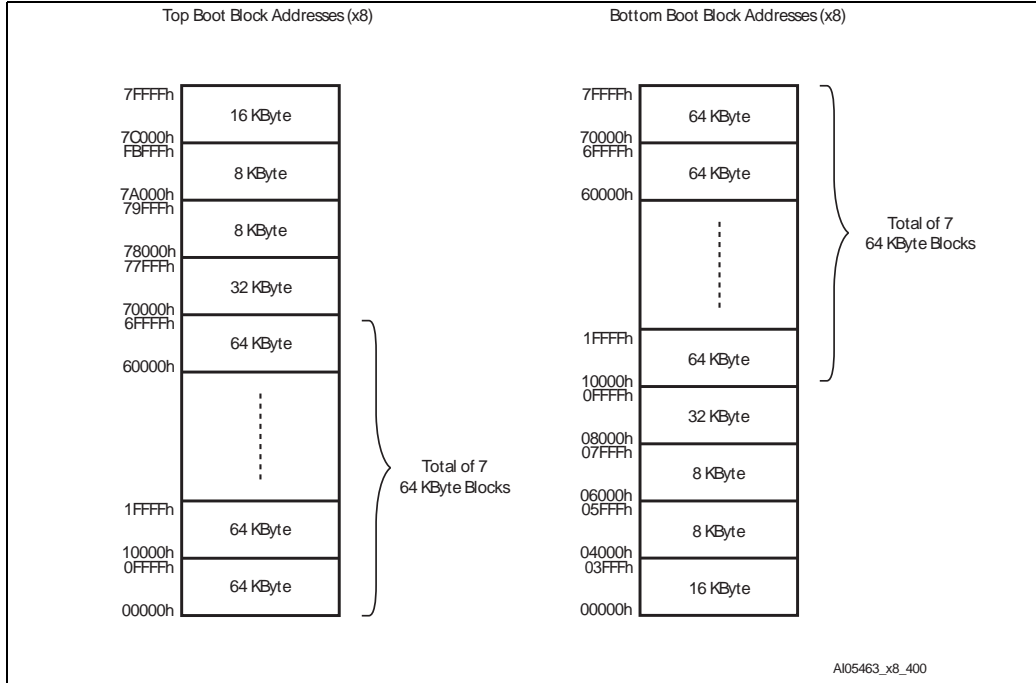

Also see Appendix [Appendix A: Block Address Table](#) for a full listing of the Block Addresses.

Figure 15. Block Addresses, M29F400 (x16)

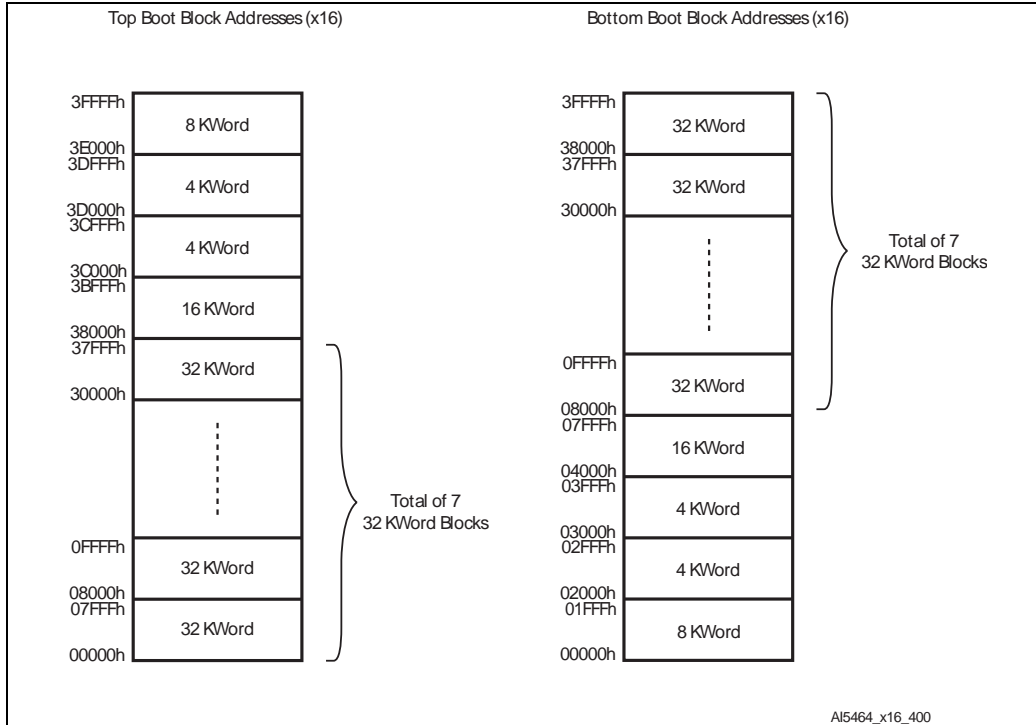

Also see Appendix [Appendix A: Block Address Table](#) for a full listing of the Block Addresses.

Figure 16. Block Addresses, M29F200 (x8)

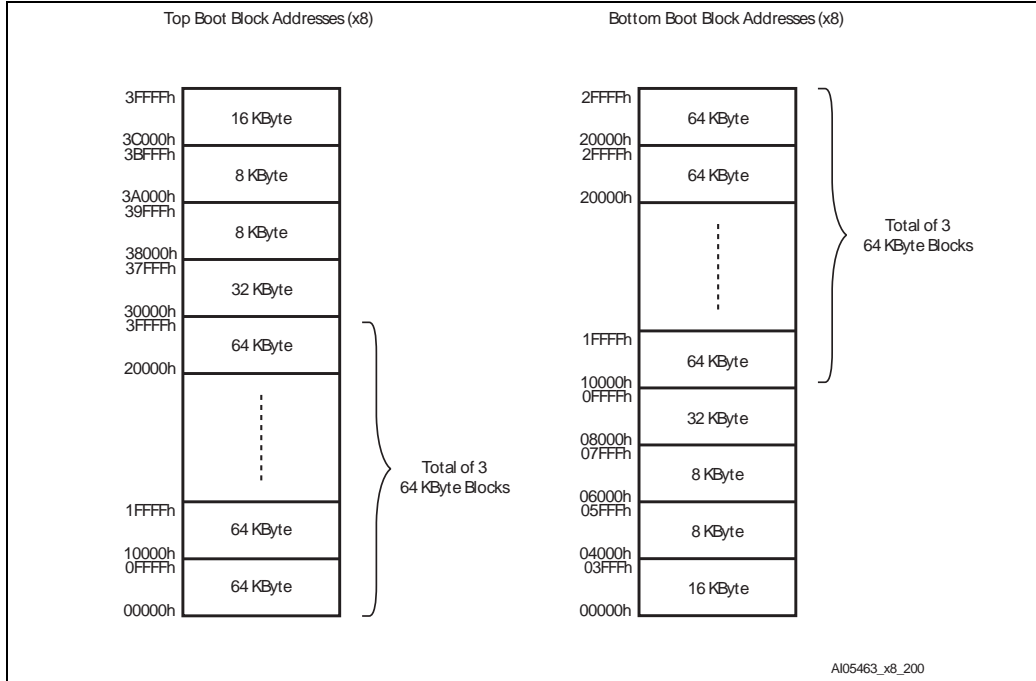

Also see Appendix [Appendix A: Block Address Table](#) for a full listing of the Block Addresses.

Figure 17. Block Addresses, M29F200 (x16)

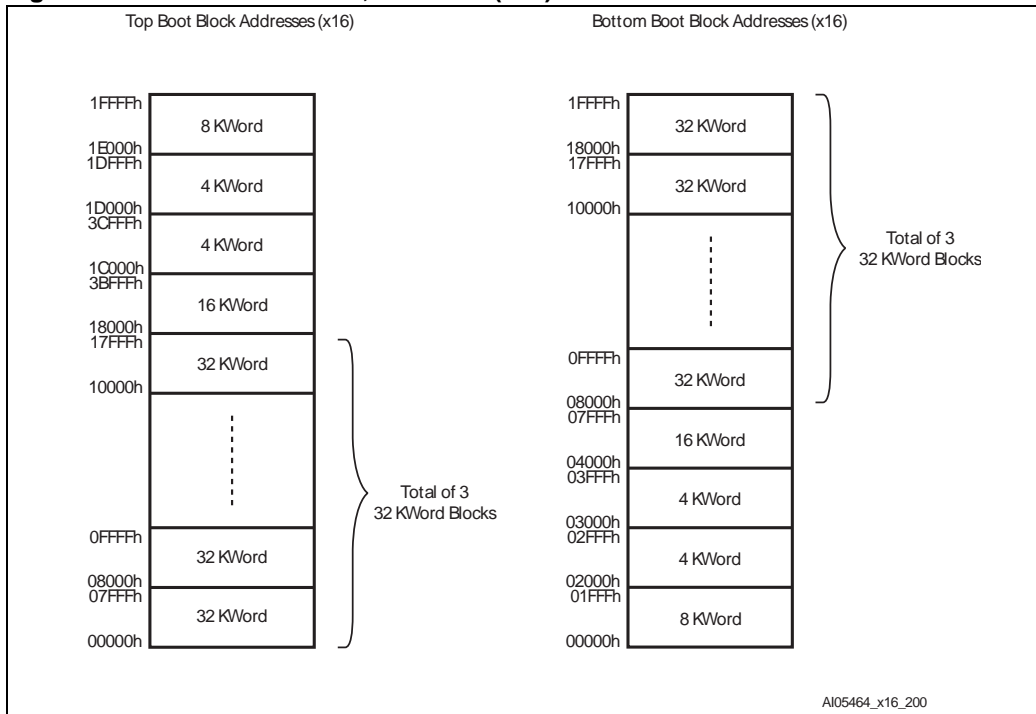

Also see Appendix [Appendix A: Block Address Table](#) for a full listing of the Block Addresses.

2 Signal Descriptions

See [Figure 1.: Logic Diagram](#) and [Table 1.: Signal Names](#), for a brief overview of the signals connected to this device.

2.1 Address Inputs (A0-A19)

The Address Inputs select the cells in the memory array to access during Bus Read operations. During Bus Write operations they control the commands sent to the Command Interface of the Program/Erase Controller.

2.2 Data Inputs/Outputs (DQ0-DQ7)

The Data Inputs/Outputs output the data stored at the selected address during a Bus Read operation. During Bus Write operations they represent the commands sent to the Command Interface of the Program/Erase Controller.

2.3 Data Inputs/Outputs (DQ8-DQ14)

The Data Inputs/Outputs output the data stored at the selected address during a Bus Read operation when $\overline{\text{BYTE}}$ is High, V_{IH} . When $\overline{\text{BYTE}}$ is Low, V_{IL} , these pins are not used and are high impedance. During Bus Write operations the Command Register does not use these bits. When reading the Status Register these bits should be ignored.

2.4 Data Input/Output or Address Input (DQ15A-1)

When $\overline{\text{BYTE}}$ is High, V_{IH} , this pin behaves as a Data Input/Output pin (as DQ8-DQ14). When $\overline{\text{BYTE}}$ is Low, V_{IL} , this pin behaves as an address pin; DQ15A-1 Low will select the LSB of the Word on the other addresses, DQ15A-1 High will select the MSB. Throughout the text consider references to the Data Input/Output to include this pin when $\overline{\text{BYTE}}$ is High and references to the Address Inputs to include this pin when $\overline{\text{BYTE}}$ is Low except when stated explicitly otherwise.

2.5 Chip Enable

The Chip Enable, $\overline{\text{E}}$, activates the memory, allowing Bus Read and Bus Write operations to be performed. When Chip Enable is High, V_{IH} , all other pins are ignored.

2.6 Output Enable

The Output Enable, $\overline{\text{G}}$, controls the Bus Read operation of the memory.

2.7 Write Enable

The Write Enable, \overline{W} , controls the Bus Write operation of the memory's Command Interface.

2.8 Reset/Block Temporary Unprotect

The Reset/Block Temporary Unprotect pin can be used to apply a Hardware Reset to the memory or to temporarily unprotect all Blocks that have been protected.

A Hardware Reset is achieved by holding Reset/Block Temporary Unprotect Low, V_{IL} , for at least t_{PLPX} . After Reset/Block Temporary Unprotect goes High, V_{IH} , the memory will be ready for Bus Read and Bus Write operations after t_{PHEL} or t_{RHEL} , whichever occurs last. See the Ready/Busy Output section, [Table 18.: Reset/Block Temporary Unprotect AC Characteristics](#) and [Figure 23.: Reset/Block Temporary Unprotect AC Waveforms](#).

Holding \overline{RP} at V_{ID} will temporarily unprotect the protected Blocks in the memory. Program and Erase operations on all blocks will be possible. The transition from V_{IH} to V_{ID} must be slower than t_{PHPHH} .

2.9 Ready/Busy Output

The Ready/Busy pin is an open-drain output that can be used to identify when the device is performing a Program or Erase operation. During Program or Erase operations Ready/Busy is Low, V_{OL} . Ready/Busy is high-impedance during Read mode, Auto Select mode and Erase Suspend mode.

After a Hardware Reset, Bus Read and Bus Write operations cannot begin until Ready/Busy becomes high-impedance. See [Table 18.: Reset/Block Temporary Unprotect AC Characteristics](#) and [Figure 23.: Reset/Block Temporary Unprotect AC Waveforms](#).

The use of an open-drain output allows the Ready/Busy pins from several memories to be connected to a single pull-up resistor. A Low will then indicate that one, or more, of the memories is busy.

2.10 Byte/Word Organization Select

The Byte/Word Organization Select pin is used to switch between the 8-bit and 16-bit Bus modes of the memory. When Byte/Word Organization Select is Low, V_{IL} , the memory is in 8-bit mode, when it is High, V_{IH} , the memory is in 16-bit mode.

2.11 V_{CC} Supply Voltage

The V_{CC} Supply Voltage supplies the power for all operations (Read, Program, Erase etc.).

The Command Interface is disabled when the V_{CC} Supply Voltage is less than the Lockout Voltage, V_{LKO} . This prevents Bus Write operations from accidentally damaging the data during power up, power down and power surges. If the Program/Erase Controller is programming or erasing during this time then the operation aborts and the memory contents being altered will be invalid.

A 0.1 μ F capacitor should be connected between the V_{CC} Supply Voltage pin and the V_{SS} Ground pin to decouple the current surges from the power supply. The PCB track widths must be sufficient to carry the currents required during program and erase operations, I_{CC3} .

2.12 V_{SS} Ground

The V_{SS} Ground is the reference for all voltage measurements. The two V_{SS} pins of the device must be connected to the system ground.

3 Bus Operations

There are five standard bus operations that control the device. These are Bus Read, Bus Write, Output Disable, Standby and Automatic Standby. See [Table 2.: Bus Operations, BYTE = VIL](#) and [Table 3.: Bus Operations, BYTE = VIH](#) for a summary. Typically glitches of less than 5ns on Chip Enable or Write Enable are ignored by the memory and do not affect bus operations.

3.1 Bus Read

Bus Read operations read from the memory cells, or specific registers in the Command Interface. A valid Bus Read operation involves setting the desired address on the Address Inputs, applying a Low signal, V_{IL} , to Chip Enable and Output Enable and keeping Write Enable High, V_{IH} . The Data Inputs/Outputs will output the value, see [Figure 20.: Read Mode AC Waveforms](#) and [Table 15.: Read AC Characteristics](#), for details of when the output becomes valid.

3.2 Bus Write

Bus Write operations write to the Command Interface. A valid Bus Write operation begins by setting the desired address on the Address Inputs. The Address Inputs are latched by the Command Interface on the falling edge of Chip Enable or Write Enable, whichever occurs last. The Data Inputs/Outputs are latched by the Command Interface on the rising edge of Chip Enable or Write Enable, whichever occurs first. Output Enable must remain High, V_{IH} , during the whole Bus Write operation. See the following figures and tables:

- [Figure 21.: Write AC Waveforms, Write Enable Controlled](#)
- [Figure 22.: Write AC Waveforms, Chip Enable Controlled](#),
- [Table 16.: Write AC Characteristics, Write Enable Controlled](#)
- [Table 17.: Write AC Characteristics, Chip Enable Controlled](#).

3.3 Output Disable

The Data Inputs/Outputs are in the high impedance state when Output Enable is High, V_{IH} .

3.4 Standby

When Chip Enable is High, V_{IH} , the memory enters Standby mode and the Data Inputs/Outputs pins are placed in the high-impedance state. To reduce the Supply Current to the Standby Supply Current, I_{CC2} , Chip Enable should be held within $V_{CC} \pm 0.2V$. For the Standby current level see [Table 14.: DC Characteristics](#).

During program or erase operations the memory will continue to use the Program/Erase Supply Current, I_{CC3} , for Program or Erase operations until the operation completes.

3.5 Automatic Standby

If CMOS levels ($V_{CC} \pm 0.2V$) are used to drive the bus and the bus is inactive for 150ns or more the memory enters Automatic Standby where the internal Supply Current is reduced to the Standby Supply Current, I_{CC2} . The Data Inputs/Outputs will still output data if a Bus Read operation is in progress.

3.6 Special Bus Operations

Additional bus operations can be performed to read the Electronic Signature and also to apply and remove Block Protection. These bus operations are intended for use by programming equipment and are not usually used in applications. They require V_{ID} to be applied to some pins.

3.7 Electronic Signature

The memory has two codes, the manufacturer code and the device code, that can be read to identify the memory. These codes can be read by applying the signals listed in [Table 2.: Bus Operations, BYTE = VIL](#) and [Table 3.: Bus Operations, BYTE = VIH](#).

3.8 Block Protection and Block Unprotection

Each block can be separately protected against accidental Program or Erase. Protected blocks can be unprotected to allow data to be changed.

There are two methods available for protecting and unprotecting the blocks, one for use on programming equipment and the other for in-system use. Block Protect and Blocks Unprotect operations are described in [Appendix C: Block protection](#).

Table 2. Bus Operations, $\overline{\text{BYTE}} = V_{\text{IL}}$

Operation	$\overline{\text{E}}$	$\overline{\text{G}}$	$\overline{\text{W}}$	Address Inputs DQ15A-1, A0-A19	Data Inputs/Outputs	
					DQ14-DQ8	DQ7-DQ0
Bus Read	V_{IL}	V_{IL}	V_{IH}	Cell Address	Hi-Z	Data Output
Bus Write	V_{IL}	V_{IH}	V_{IL}	Command Address	Hi-Z	Data Input
Output Disable	X	V_{IH}	V_{IH}	X	Hi-Z	Hi-Z
Standby	V_{IH}	X	X	X	Hi-Z	Hi-Z
Read Manufacturer Code	V_{IL}	V_{IL}	V_{IH}	A0 = V_{IL} , A1 = V_{IL} , A9 = V_{ID} , Others V_{IL} or V_{IH}	Hi-Z	0x01
Read Device Code	V_{IL}	V_{IL}	V_{IH}	A0 = V_{IH} , A1 = V_{IL} , A9 = V_{ID} , Others V_{IL} or V_{IH}	Hi-Z	0x51 (M29F200FT) 0x57 (M29F200FB) 0x23 (M29F400FT) 0xAB (M29F400FB) 0xD6 (M29F800FT) 0x58 (M29F800FB) 0xD2 (M29F160FT) 0xD8 (M29F160FB)

X = V_{IL} or V_{IH} .Table 3. Bus Operations, $\overline{\text{BYTE}} = V_{\text{IH}}$

Operation	$\overline{\text{E}}$	$\overline{\text{G}}$	$\overline{\text{W}}$	Address Inputs A0-A19	Data Inputs/Outputs DQ15A-1, DQ14-DQ0
					DQ15A-1, DQ14-DQ0
Bus Read	V_{IL}	V_{IL}	V_{IH}	Cell Address	Data Output
Bus Write	V_{IL}	V_{IH}	V_{IL}	Command Address	Data Input
Output Disable	X	V_{IH}	V_{IH}	X	Hi-Z
Standby	V_{IH}	X	X	X	Hi-Z
Read Manufacturer Code	V_{IL}	V_{IL}	V_{IH}	A0 = V_{IL} , A1 = V_{IL} , A9 = V_{ID} , Others V_{IL} or V_{IH}	0x01
Read Device Code	V_{IL}	V_{IL}	V_{IH}	A0 = V_{IH} , A1 = V_{IL} , A9 = V_{ID} , Others V_{IL} or V_{IH}	0x2251 (M29F200FT) 0x2257 (M29F200FB) 0x2223 (M29F400FT) 0x22AB (M29F400FB) 0x22D6 (M29F800FT) 0x2258 (M29F800FB) 0x22D2 (M29F160FT) 0x22D8 (M29F160FB)

X = V_{IL} or V_{IH} .

4 Command Interface

All Bus Write operations to the memory are interpreted by the Command Interface. Commands consist of one or more sequential Bus Write operations. Failure to observe a valid sequence of Bus Write operations will result in the memory returning to Read mode. The long command sequences are imposed to maximize data security.

The address used for the commands changes depending on whether the memory is in 16-bit or 8-bit mode. See either [Table 4.: Commands, 16-bit mode, BYTE = VIH](#), or [Table 5.: Commands, 8-bit mode, BYTE = VIL](#), depending on the configuration that is being used, for a summary of the commands.

4.1 Read/Reset Command

The Read/Reset command returns the memory to its Read mode where it behaves like a ROM or EPROM, unless otherwise stated. It also resets the errors in the Status Register. Either one or three Bus Write operations can be used to issue the Read/Reset command.

The Read/Reset Command can be issued, between Bus Write cycles before the start of a program or erase operation, to return the device to read mode. Once the program or erase operation has started the Read/Reset command is no longer accepted. The Read/Reset command will not abort an Erase operation when issued while in Erase Suspend.

4.2 Auto Select Command

The Auto Select command is used to read the Manufacturer Code, the Device Code and the Block Protection Status. Three consecutive Bus Write operations are required to issue the Auto Select command. Once the Auto Select command is issued the memory remains in Auto Select mode until a Read/Reset command is issued. Read CFI Query and Read/Reset commands are accepted in Auto Select mode, all other commands are ignored.

From the Auto Select mode the Manufacturer Code can be read using a Bus Read operation with $A0 = V_{IL}$ and $A1 = V_{IL}$. The other address bits may be set to either V_{IL} or V_{IH} . The Manufacturer Code for Numonyx is 0001h.

The Device Code can be read using a Bus Read operation with $A0 = V_{IH}$ and $A1 = V_{IL}$. The other address bits may be set to either V_{IL} or V_{IH} .

The Block Protection Status of each block can be read using a Bus Read operation with $A0 = V_{IL}$, $A1 = V_{IH}$, and A12-A19 specifying the address of the block. The other address bits may be set to either V_{IL} or V_{IH} . If the addressed block is protected then 01h is output on Data Inputs/Outputs DQ0-DQ7, otherwise 00h is output.

4.3 Program Command

The Program command can be used to program a value to one address in the memory array at a time. The command requires four Bus Write operations, the final write operation latches the address and data, and starts the Program/Erase Controller.

If the address falls in a protected block then the Program command is ignored, the data remains unchanged. The Status Register is never read and no error condition is given.

During the program operation the memory will ignore all commands. It is not possible to issue any command to abort or pause the operation. Typical program times are given in [Table 6.: Program/Erase Times and Program/Erase Endurance Cycles, M29F160F](#). Bus Read operations during the program operation will output the Status Register on the Data Inputs/Outputs. See the section on the Status Register for more details.

After the program operation has completed the memory returns to the Read mode, unless an error has occurred. When an error occurs the memory continues to output the Status Register. A Read/Reset command must be issued to reset the error condition and return to Read mode.

Note that the Program command cannot change a bit set at '0' back to '1'. One of the Erase Commands must be used to set all the bits in a block or in the whole memory from '0' to '1'.

4.4 Unlock Bypass Command

The Unlock Bypass command is used in conjunction with the Unlock Bypass Program command to program the memory. When the access time to the device is long (as with some EPROM programmers) considerable time saving can be made by using these commands. Three Bus Write operations are required to issue the Unlock Bypass command.

Once the Unlock Bypass command has been issued the memory will only accept the Unlock Bypass Program command and the Unlock Bypass Reset command. The memory can be read as if in Read mode.

4.5 Unlock Bypass Program Command

The Unlock Bypass Program command can be used to program one address in memory at a time. The command requires two Bus Write operations, the final write operation latches the address and data, and starts the Program/Erase Controller.

The Program operation using the Unlock Bypass Program command behaves identically to the Program operation using the Program command. A protected block cannot be programmed; the operation cannot be aborted and the Status Register is read. Errors must be reset using the Read/Reset command, which leaves the device in Unlock Bypass Mode. See the Program command for details on the behavior.

4.6 Unlock Bypass Reset Command

The Unlock Bypass Reset command can be used to return to Read/Reset mode from Unlock Bypass Mode. Two Bus Write operations are required to issue the Unlock Bypass Reset command. Read/Reset command does not exit from Unlock Bypass Mode.

4.7 Chip Erase Command

The Chip Erase command can be used to erase the entire chip. Six Bus Write operations are required to issue the Chip Erase Command and start the Program/Erase Controller.

If any blocks are protected then these are ignored and all the other blocks are erased. If all of the blocks are protected the Chip Erase operation appears to start but will terminate

within about 100 μ s, leaving the data unchanged. No error condition is given when protected blocks are ignored.

During the erase operation the memory will ignore all commands. It is not possible to issue any command to abort the operation. Typical chip erase times are given in [Table 6.: Program/Erase Times and Program/Erase Endurance Cycles, M29F160F](#). All Bus Read operations during the Chip Erase operation will output the Status Register on the Data Inputs/Outputs. See the section on the Status Register for more details.

After the Chip Erase operation has completed the memory will return to the Read Mode, unless an error has occurred. When an error occurs the memory will continue to output the Status Register. A Read/Reset command must be issued to reset the error condition and return to Read Mode.

The Chip Erase Command sets all of the bits in unprotected blocks of the memory to '1'. All previous data is lost.

4.8 Block Erase Command

The Block Erase command can be used to erase a list of one or more blocks. Six Bus Write operations are required to select the first block in the list. Each additional block in the list can be selected by repeating the sixth Bus Write operation using the address of the additional block. The Block Erase operation starts the Program/Erase Controller about 50 μ s after the last Bus Write operation. Once the Program/Erase Controller starts it is not possible to select any more blocks. Each additional block must therefore be selected within 50 μ s of the last block. The 50 μ s timer restarts when an additional block is selected. The Status Register can be read after the sixth Bus Write operation. See the Status Register section for details on how to identify if the Program/Erase Controller has started the Block Erase operation.

If any selected blocks are protected then these are ignored and all the other selected blocks are erased. If all of the selected blocks are protected the Block Erase operation appears to start but will terminate within about 100 μ s, leaving the data unchanged. No error condition is given when protected blocks are ignored.

During the Block Erase operation the memory will ignore all commands except the Erase Suspend command. Typical block erase times are given in [Table 6.: Program/Erase Times and Program/Erase Endurance Cycles, M29F160F](#). All Bus Read operations during the Block Erase operation will output the Status Register on the Data Inputs/Outputs. See the section on the Status Register for more details.

After the Block Erase operation has completed the memory will return to the Read Mode, unless an error has occurred. When an error occurs the memory will continue to output the Status Register. A Read/Reset command must be issued to reset the error condition and return to Read mode.

The Block Erase Command sets all of the bits in the unprotected selected blocks to '1'. All previous data in the selected blocks is lost.

4.9 Erase Suspend Command

The Erase Suspend Command may be used to temporarily suspend a Block Erase operation and return the memory to Read mode. The command requires one Bus Write operation.

The Program/Erase Controller will suspend within the Erase Suspend Latency Time (refer to [Table 6.: Program/Erase Times and Program/Erase Endurance Cycles, M29F160F](#) for value) of the Erase Suspend Command being issued. Once the Program/Erase Controller has stopped the memory will be set to Read mode and the Erase will be suspended. If the Erase Suspend command is issued during the period when the memory is waiting for an additional block (before the Program/Erase Controller starts) then the Erase is suspended immediately and will start immediately when the Erase Resume Command is issued. It is not possible to select any further blocks to erase after the Erase Resume.

During Erase Suspend it is possible to Read and Program cells in blocks that are not being erased; both Read and Program operations behave as normal on these blocks. If any attempt is made to program in a protected block or in the suspended block then the Program command is ignored and the data remains unchanged. The Status Register is not read and no error condition is given. Reading from blocks that are being erased will output the Status Register.

It is also possible to issue the Auto Select, Read CFI Query and Unlock Bypass commands during an Erase Suspend. The Read/Reset command must be issued to return the device to Read Array mode before the Resume command will be accepted.

4.10 Erase Resume Command

The Erase Resume command must be used to restart the Program/Erase Controller from Erase Suspend. An erase can be suspended and resumed more than once.

4.11 Read CFI Query Command

The Read CFI Query Command is used to read data from the Common Flash Interface (CFI) Memory Area. This command is valid when the device is in the Read Array mode, or when the device is in Auto Select mode.

One Bus Write cycle is required to issue the Read CFI Query Command. Once the command is issued subsequent Bus Read operations read from the Common Flash Interface Memory Area.

The Read/Reset command must be issued to return the device to the previous mode (the Read Array mode or Auto Select mode). A second Read/Reset command would be needed if the device is to be put in the Read Array mode from Auto Select mode.

See [Appendix B: Common Flash Interface \(CFI\)](#) and the following tables for details on the information contained in the Common Flash Interface (CFI) memory area.

- [Table 31.: Query Structure Overview](#),
- [Table 32.: CFI Query Identification String](#),
- [Table 33.: CFI Query System Interface Information](#),
- [Table 34.: Device Geometry Definition](#),
- [Table 35.: Primary Algorithm-Specific Extended Query Table](#)
- [Table 36.: Security Code Area](#)

Table 4. Commands, 16-bit mode, $\overline{\text{BYTE}} = V_{IH}$

Command	Length	Bus Write Operations											
		1st		2nd		3rd		4th		5th		6th	
		Addr	Addr	Addr	Addr	Addr	Addr	Addr	Addr	Addr	Addr	Addr	Addr
Read/Reset	1	X	F0										
	3	555	AA	2AA	55	X	F0						
Auto Select	3	555	AA	2AA	55	555	90						
Program	4	555	AA	2AA	55	555	A0	PA	PD				
Unlock Bypass	3	555	AA	2AA	55	555	20						
Unlock Bypass Program	2	X	A0	PA	PD								
Unlock Bypass Reset	2	X	90	X	00								
Chip Erase	6	555	AA	2AA	55	555	80	555	AA	2AA	55	555	10
Block Erase	6+	555	AA	2AA	55	555	80	555	AA	2AA	55	BA	30
Erase Suspend	1	X	B0										
Erase Resume	1	X	30										
Read CFI Query	1	55	98										

X Don't Care, PA Program Address, PD Program Data, BA Any address in the Block. All values in the table are in hexadecimal.

Command Interface: only uses A-1, A0-A10 and DQ0-DQ7 to verify the commands; A11-A19, DQ8-DQ14 and DQ15 are Don't Care. DQ15A-1 is A-1 when BYTE is V_{IL} or DQ15 when BYTE is V_{IH} .

Read/Reset: After a Read/Reset command, read the memory as normal until another command is issued.

Auto Select: After an Auto Select command, read Manufacturer ID, Device ID or Block Protection Status.

Program, Unlock Bypass Program, Chip Erase, Block Erase: After these commands read the Status Register until the Program/Erase Controller completes and the memory returns to Read Mode. Add additional Blocks during Block Erase Command with additional Bus Write Operations until Timeout Bit is set.

Unlock Bypass: After the Unlock Bypass command issue Unlock Bypass Program or Unlock Bypass Reset commands.

Unlock Bypass Reset: After the Unlock Bypass Reset command read the memory as normal until another command is issued.

Erase Suspend: After the Erase Suspend command read non-erasing memory blocks as normal, issue Auto Select and Program commands on non-erasing blocks as normal.

Erase Resume: After the Erase Resume command the suspended Erase operation resumes, read the Status Register until the Program/Erase Controller completes and the memory returns to Read Mode.

CFI Query: Command is valid when device is ready to read array data or when device is in Auto Select mode.

Table 5. Commands, 8-bit mode, $\overline{\text{BYTE}} = V_{\text{IL}}$

Command	Length	Bus Write Operations											
		1st		2nd		3rd		4th		5th		6th	
		Addr	Data	Addr	Data	Addr	Data	Addr	Data	Addr	Data	Addr	Data
Read/Reset	1	X	F0										
	3	AAA	AA	555	55	X	F0						
Auto Select	3	AAA	AA	555	55	AAA	90						
Program	4	AAA	AA	555	55	AAA	A0	PA	PD				
Unlock Bypass	3	AAA	AA	555	55	AAA	20						
Unlock Bypass Program	2	X	A0	PA	PD								
Unlock Bypass Reset	2	X	90	X	00								
Chip Erase	6	AAA	AA	555	55	AAA	80	AAA	AA	555	55	AAA	10
Block Erase	6+	AAA	AA	555	55	AAA	80	AAA	AA	555	55	BA	30
Erase Suspend	1	X	B0										
Erase Resume	1	X	30										
Read CFI Query	1	AA	98										

X Don't Care, PA Program Address, PD Program Data, BA Any address in the Block. All values in the table are in hexadecimal.

Command Interface: only uses A-1, A0-A10 and DQ0-DQ7 to verify the commands; A11-A19, DQ8-DQ14 and DQ15 are Don't Care. DQ15A-1 is A-1 when BYTE is V_{IL} or DQ15 when BYTE is V_{IH} .

Read/Reset: After a Read/Reset command, read the memory as normal until another command is issued.

Auto Select: After an Auto Select command, read Manufacturer ID, Device ID or Block Protection Status.

Program, Unlock Bypass Program, Chip Erase, Block Erase: After these commands read the Status Register until the Program/Erase Controller completes and the memory returns to Read Mode. Add additional Blocks during Block Erase Command with additional Bus Write Operations until Timeout Bit is set.

Unlock Bypass: After the Unlock Bypass command issue Unlock Bypass Program or Unlock Bypass Reset commands.

Unlock Bypass Reset: After the Unlock Bypass Reset command read the memory as normal until another command is issued.

Erase Suspend: After the Erase Suspend command read non-erasing memory blocks as normal, issue Auto Select and Program commands on non-erasing blocks as normal.

Erase Resume: After the Erase Resume command the suspended Erase operation resumes, read the Status Register until the Program/Erase Controller completes and the memory returns to Read Mode.

CFI Query: Command is valid when device is ready to read array data or when device is in Auto Select mode.

Table 6. Program/Erase Times and Program/Erase Endurance Cycles, M29F160F

Parameter	Min	Typical	Max	Unit
Chip Erase	—	25	120	s
Block Erase (64 KBytes)	—	0.8	6	s
Erase Suspend Latency Time	—	20	25	μs
Program (Byte or Word)	—	11	200	μs
Chip Program (Byte by Byte)	—	24	120	s
Chip Program (Word by Word)	—	12	60	s
Program/Erase Cycles (per Block)	100,000	—	—	cycles
Data Retention	20	—	—	years

Typical values are measured at room temperature and nominal voltages; typical and maximum values are samples, not 100% tested.

Chip Erase, Program, and Chip Program parameters: Maximum value measured at worst case conditions for both temperature and V_{CC} after 100,000 program/erase cycles.

Block Erase and Erase Suspend Latency parameters: Maximum value measured at worst case conditions for both temperature and V_{CC} .

Table 7. Program/Erase Times and Program/Erase Endurance Cycles, M29F800F

Parameter	Min	Typical	Max	Unit
Chip Erase	—	12	60	s
Block Erase (64 KBytes)	—	0.8	6	s
Erase Suspend Latency Time	—	20	25	μs
Program (Byte or Word)	—	11	200	μs
Chip Program (Byte by Byte)	—	12	—	s
Chip Program (Word by Word)	—	6	30	s
Program/Erase Cycles (per Block)	100,000	—	—	cycles
Data Retention	20	—	—	years

Typical values are measured at room temperature and nominal voltages; typical and maximum values are samples, not 100% tested.

Chip Erase, Program, and Chip Program parameters: Maximum value measured at worst case conditions for both temperature and V_{CC} after 100,000 program/erase cycles.

Block Erase and Erase Suspend Latency parameter: Maximum value measured at worst case conditions for both temperature and V_{CC} .

Table 8. Program/Erase Times and Program/Erase Endurance Cycles, M29F400F

Parameter	Min	Typical	Max	Unit
Chip Erase	—	6	30	s
Block Erase (64 KBytes)	—	0.8	6	s
Erase Suspend Latency Time	—	20	25	μs
Program (Byte or Word)	—	11	200	μs
Chip Program (Byte by Byte)	—	6	—	s
Chip Program (Word by Word)	—	3	15	s
Program/Erase Cycles (per Block)	100,000	—	—	cycles
Data Retention	20	—	—	years

Typical values are measured at room temperature and nominal voltages; typical and maximum values are samples, not 100% tested.

Chip Erase, Program, and Chip Program parameters: Maximum value measured at worst case conditions for both temperature and V_{CC} after 100,000 program/erase cycles.

Block Erase and Erase Suspend Latency parameter: Maximum value measured at worst case conditions for both temperature and V_{CC} .

Table 9. Program/Erase Times and Program/Erase Endurance Cycles, M29F200F

Parameter	Min	Typical	Max	Unit
Chip Erase	—	3	15	s
Block Erase (64 KBytes)	—	0.8	6	s
Erase Suspend Latency Time	—	20	25	μs
Program (Byte or Word)	—	11	200	μs
Chip Program (Byte by Byte)	—	4	—	s
Chip Program (Word by Word)	—	2	8	s
Program/Erase Cycles (per Block)	100,000	—	—	cycles
Data Retention	20	—	—	years

Typical values are measured at room temperature and nominal voltages; typical and maximum values are samples, not 100% tested.

Chip Erase, Program, and Chip Program parameters: Maximum value measured at worst case conditions for both temperature and V_{CC} after 100,000 program/erase cycles.

Block Erase and Erase Suspend Latency parameter: Maximum value measured at worst case conditions for both temperature and V_{CC} .

5 Status Register

Bus Read operations from any address always read the Status Register during Program and Erase operations. It is also read during Erase Suspend when an address within a block being erased is accessed.

The bits in the Status Register are summarized in [Table 10.: Status Register Bits](#).

5.1 Data Polling Bit

The Data Polling Bit ($\overline{DQ7}$) can be used to identify whether the Program/Erase Controller has successfully completed its operation or if it has responded to an Erase Suspend. The Data Polling Bit is output on DQ7 when the Status Register is read.

During Program operations the Data Polling Bit outputs the complement of the bit being programmed to DQ7. After successful completion of the Program operation the memory returns to Read mode and Bus Read operations from the address just programmed output DQ7, not its complement.

During Erase operations the Data Polling Bit outputs '0', the complement of the erased state of DQ7. After successful completion of the Erase operation the memory returns to Read Mode.

In Erase Suspend mode the Data Polling Bit will output a '1' during a Bus Read operation within a block being erased. The Data Polling Bit will change from a '0' to a '1' when the Program/Erase Controller has suspended the Erase operation.

[Figure 1](#). Data Polling Flowchart, gives an example of how to use the Data Polling Bit. A Valid Address is the address being programmed or an address within the block being erased.

5.2 Toggle Bit

The Toggle Bit (DQ6) can be used to identify whether the Program/Erase Controller has successfully completed its operation or if it has responded to an Erase Suspend. The Toggle Bit is output on DQ6 when the Status Register is read.

During Program and Erase operations the Toggle Bit changes from '0' to '1' to '0', etc., with successive Bus Read operations at any address. After successful completion of the operation the memory returns to Read mode.

During Erase Suspend mode the Toggle Bit will output when addressing a cell within a block being erased. The Toggle Bit will stop toggling when the Program/Erase Controller has suspended the Erase operation.

If any attempt is made to erase a protected block, the operation is aborted, no error is signalled and DQ6 toggles for approximately 100 μ s. If any attempt is made to program a protected block or a suspended block, the operation is aborted, no error is signalled and DQ6 toggles for approximately 1 μ s.

[Figure 2](#). Data Toggle Flowchart, gives an example of how to use the Data Toggle Bit.

5.3 Error Bit

The Error Bit (DQ5) can be used to identify errors detected by the Program/Erase Controller. The Error Bit is set to '1' when a Program, Block Erase or Chip Erase operation fails to write the correct data to the memory. If the Error Bit is set a Read/Reset command must be issued before other commands are issued. The Error bit is output on DQ5 when the Status Register is read.

Note that the Program command cannot change a bit set to '0' back to '1' and attempting to do so will set DQ5 to '1'. A Bus Read operation to that address will show the bit is still '0'. One of the Erase commands must be used to set all the bits in a block or in the whole memory from '0' to '1'

5.4 Erase Timer Bit

The Erase Timer Bit (DQ3) can be used to identify the start of Program/Erase Controller operation during a Block Erase command. Once the Program/Erase Controller starts erasing the Erase Timer Bit is set to '1'. Before the Program/Erase Controller starts the Erase Timer Bit is set to '0' and additional blocks to be erased may be written to the Command Interface. The Erase Timer Bit is output on DQ3 when the Status Register is read.

5.5 Alternative Toggle Bit

The Alternative Toggle Bit (DQ2) can be used to monitor the Program/Erase controller during Erase operations. The Alternative Toggle Bit is output on DQ2 when the Status Register is read.

During Chip Erase and Block Erase operations the Toggle Bit changes from '0' to '1' to '0', etc., with successive Bus Read operations from addresses within the blocks being erased. A protected block is treated the same as a block not being erased. Once the operation completes the memory returns to Read mode.

During Erase Suspend the Alternative Toggle Bit changes from '0' to '1' to '0', etc. with successive Bus Read operations from addresses within the blocks being erased. Bus Read operations to addresses within blocks not being erased will output the memory cell data as if in Read mode.

After an Erase operation that causes the Error Bit to be set the Alternative Toggle Bit can be used to identify which block or blocks have caused the error. The Alternative Toggle Bit changes from '0' to '1' to '0', etc. with successive Bus Read Operations from addresses within blocks that have not erased correctly. The Alternative Toggle Bit does not change if the addressed block has erased correctly.

Table 10. Status Register Bits

Operation	Address	DQ7	DQ6	DQ5	DQ3	DQ2	\overline{RB}
Program	Any Address	$\overline{DQ7}$	Toggle	0	–	–	0
Program During Erase Suspend	Any Address	$\overline{DQ7}$	Toggle	0	–	–	0
Program Error	Any Address	$\overline{DQ7}$	Toggle	1	–	–	0
Chip Erase	Any Address	0	Toggle	0	1	Toggle	0
Block Erase before timeout	Erasing Block	0	Toggle	0	0	Toggle	0
	Non-Erasing Block	0	Toggle	0	0	No Toggle	0
Block Erase	Erasing Block	0	Toggle	0	1	Toggle	0
	Non-Erasing Block	0	Toggle	0	1	No Toggle	0
Erase Suspend	Erasing Block	1	No Toggle	0	–	Toggle	1
	Non-Erasing Block	Data read as normal					
Erase Error	Good Block Address	0	Toggle	1	1	No Toggle	0
	Faulty Block Address	0	Toggle	1	1	Toggle	0

Unspecified data bits should be ignored.

Figure 1. Data Polling Flowchart

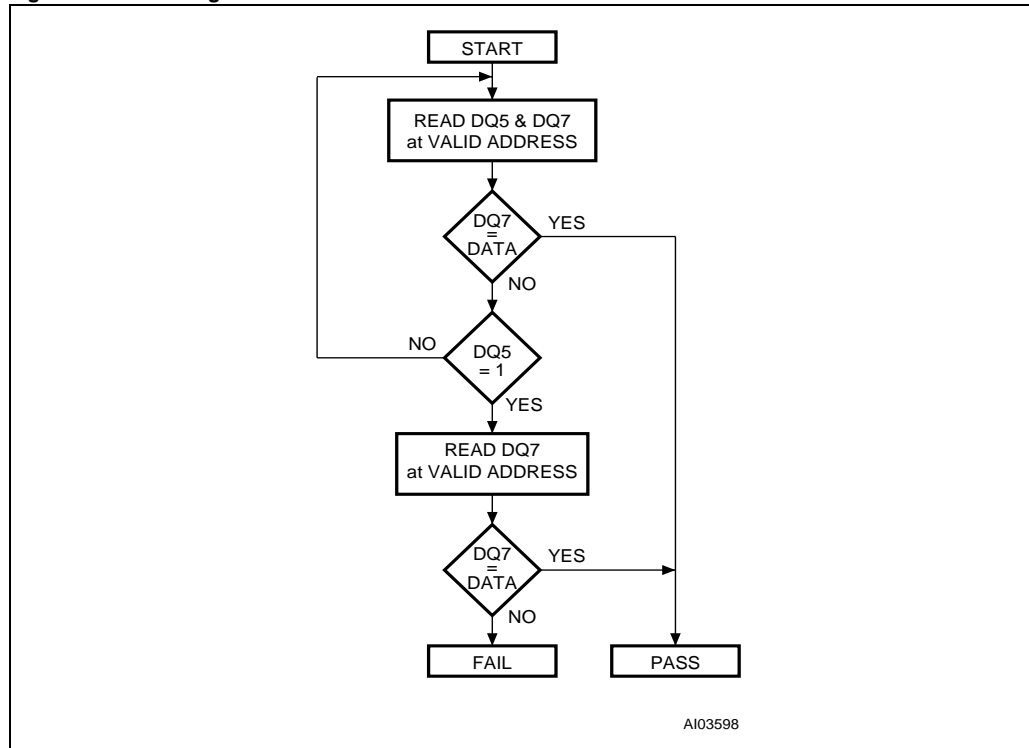
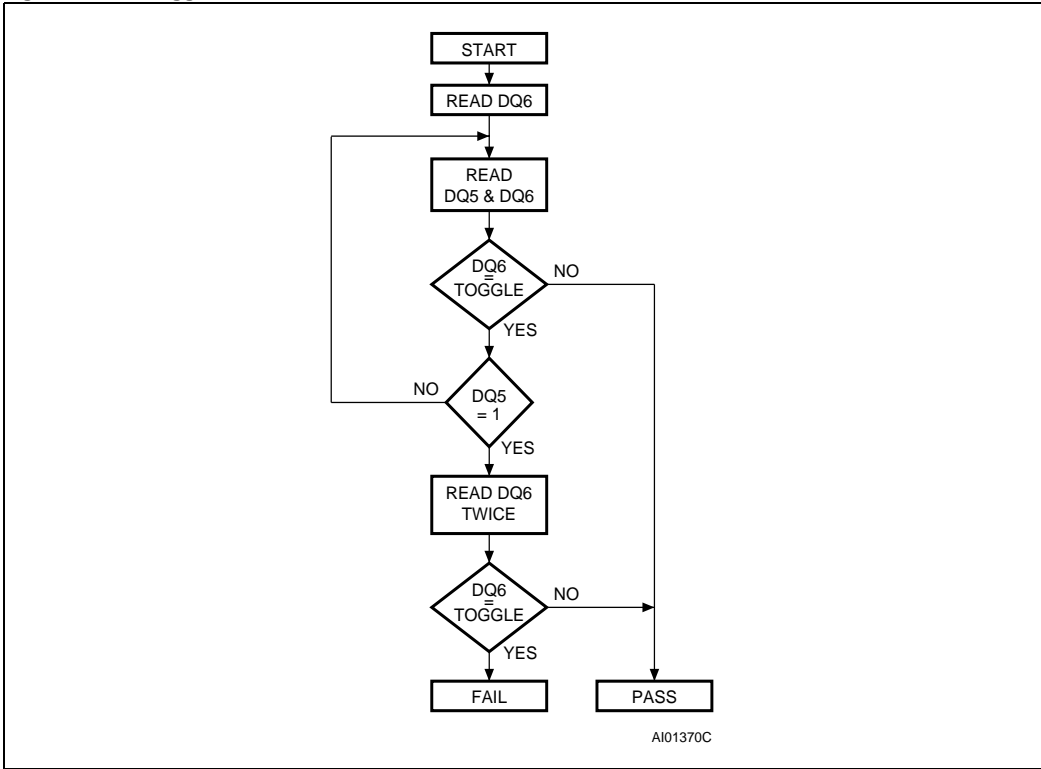

Figure 2. Data Toggle Flowchart



6 Maximum Rating

Stressing the device above the rating listed in the Absolute Maximum Ratings table may cause permanent damage to the device. Exposure to Absolute Maximum Rating conditions for extended periods may affect device reliability. These are stress ratings only and operation of the device at these or any other conditions above those indicated in the Operating sections of this specification is not implied. Refer also to the Numonyx SURE Program and other relevant quality documents.

Table 11. Absolute Maximum Ratings

Symbol	Parameter	Min	Max	Unit
T_{BIAS}	Temperature Under Bias	-50	125	°C
T_{STG}	Storage Temperature	-65	150	°C
V_{IO}	Input or Output Voltage	-0.6	$V_{CC} + 0.6$	V
V_{CC}	Supply Voltage	-0.6	6	V
V_{ID}	Identification Voltage	-0.6	13.5	V

Input or Output Voltage parameter: Minimum voltage may undershoot to -2V during transition and for less than 20ns during transitions.

Input or Output Voltage parameter: Maximum voltage may overshoot to $V_{CC} + 2V$ during transition and for less than 20ns during transitions.

7 DC and AC Parameters

This section summarizes the operating measurement conditions, and the DC and AC characteristics of the device. The parameters in the DC and AC characteristics Tables that follow, are derived from tests performed under the Measurement Conditions shown here. Designers should check that the operating conditions in their circuit match the operating conditions when relying on the quoted parameters.

Table 12. Operating and AC Measurement Conditions

Parameter	Min	Max	Unit
V_{CC} Supply Voltage	4.5	5.5	V
Ambient Operating Temperature	-40	125	°C
Load Capacitance (C_L)	30	30	pF
Input Rise and Fall Times	—	5	ns
Input Pulse Voltages	0 to V_{CC}	0 to V_{CC}	V
Input and Output Timing Ref. Voltages	$V_{CC}/2$	$V_{CC}/2$	V

Figure 18. AC Measurement I/O Waveform

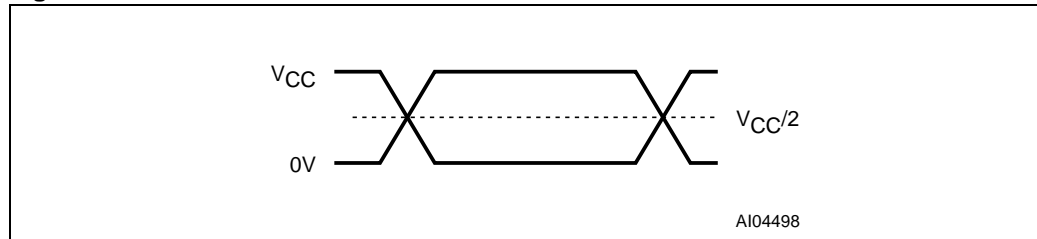

Figure 19. AC Measurement Load Circuit

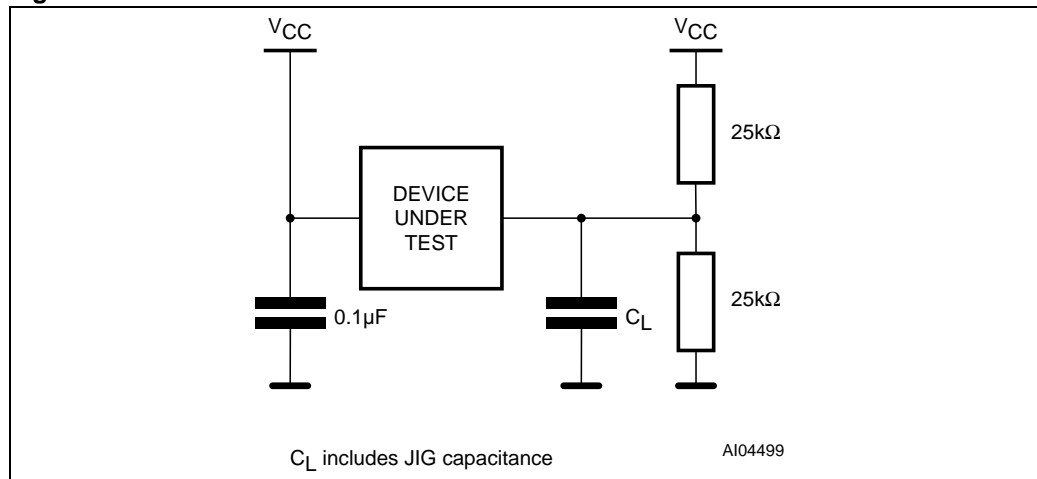

Table 13. Device Capacitance

Symbol	Parameter	Test Condition	Min	Max	Unit
C _{IN}	Input Capacitance	V _{IN} = 0V		6	pF
C _{OUT}	Output Capacitance	V _{OUT} = 0V		12	pF

Sampled only, not 100% tested.

Table 14. DC Characteristics

Symbol	Parameter	Test Condition	Min	Typ	Max	Unit
I _{LI}	Input Leakage Current	0V ≤ V _{IN} ≤ V _{CC}	—	—	±1	μA
I _{LO}	Output Leakage Current	0V ≤ V _{OUT} ≤ V _{CC}	—	—	±1	μA
I _{CC1}	Supply Current (Read)	$\bar{E} = V_{IL}, \bar{G} = V_{IH}, f = 6\text{MHz}$	—	7	20	mA
I _{CC2}	Supply Current (Standby)	$\bar{E} = V_{CC} \pm 0.2\text{V}, \bar{R}\bar{P} = V_{CC} \pm 0.2\text{V}$	—	60	120	μA
I _{CC3}	Supply Current (Program/Erase)	Program/Erase Controller active	—	—	30	mA
V _{IL}	Input Low Voltage	—	-0.5	—	0.8	V
V _{IH}	Input High Voltage	—	0.7V _{CC}	—	V _{CC} + 0.3	V
V _{OL}	Output Low Voltage	I _{OL} = 1.8mA	—	—	0.45	V
V _{OH}	Output High Voltage	I _{OH} = -100μA	V _{CC} - 0.4	—	—	V
V _{ID}	Identification Voltage	—	11.5	—	12.5	V
I _{ID}	Identification Current	A9 = V _{ID}	—	—	100	μA
V _{LKO}	Program/Erase Lockout Supply Voltage	—	1.8	—	2.3	V

Supply Current (Program/Erase) parameter: Sampled only, not 100% tested.

Figure 20. Read Mode AC Waveforms

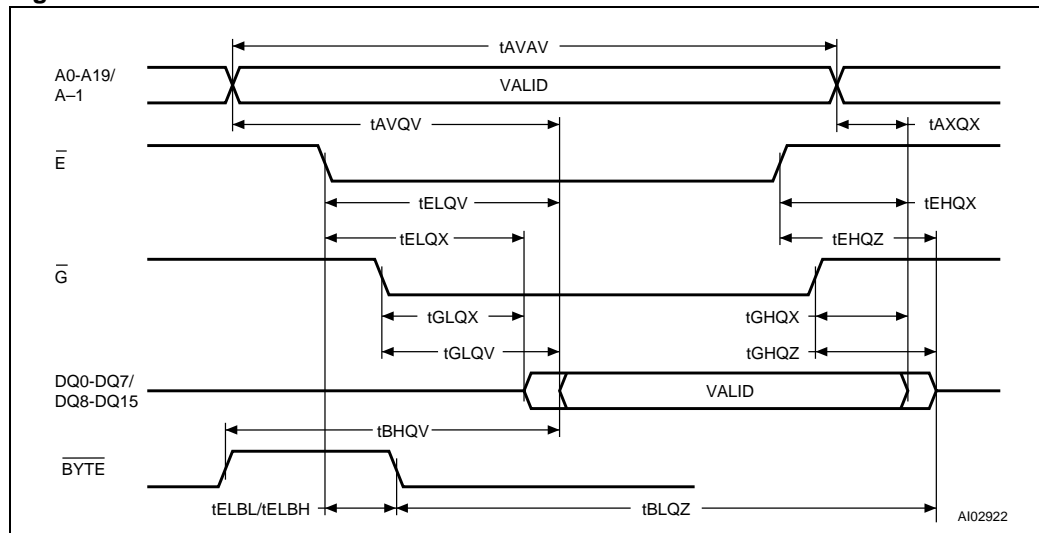

Table 15. Read AC Characteristics

Symbol	Alt	Parameter	Test Condition		M29F160F	Unit
					55/5A	
t_{AVAV}	t_{RC}	Address Valid to Next Address Valid	$\overline{E} = V_{IL}$, $\overline{G} = V_{IL}$	Min	55	ns
t_{AVQV}	t_{ACC}	Address Valid to Output Valid	$\overline{E} = V_{IL}$, $\overline{G} = V_{IL}$	Max	55	ns
t_{ELQX}	t_{LZ}	Chip Enable Low to Output Transition	$\overline{G} = V_{IL}$	Min	0	ns
t_{ELQV}	t_{CE}	Chip Enable Low to Output Valid	$\overline{G} = V_{IL}$	Max	55	ns
t_{GLQX}	t_{OLZ}	Output Enable Low to Output Transition	$\overline{E} = V_{IL}$	Min	0	ns
t_{GLQV}	t_{OE}	Output Enable Low to Output Valid	$\overline{E} = V_{IL}$	Max	20	ns
t_{EHQZ}	t_{HZ}	Chip Enable High to Output Hi-Z	$\overline{G} = V_{IL}$	Max	15	ns
t_{GHQZ}	t_{DF}	Output Enable High to Output Hi-Z	$\overline{E} = V_{IL}$	Max	15	ns
t_{EHQX} t_{GHQX} t_{AXQX}	t_{OH}	Chip Enable, Output Enable or Address Transition to Output Transition	—	Min	0	ns
t_{ELBL} t_{ELBH}	t_{ELFL} t_{ELFH}	Chip Enable to \overline{BYTE} Low or High	—	Max	3	ns
t_{BLQZ}	t_{FLQZ}	\overline{BYTE} Low to Output Hi-Z	—	Max	15	ns
t_{BHQV}	t_{FHQV}	\overline{BYTE} High to Output Valid	—	Max	20	ns

t_{ELQX} t_{GLQX} t_{EHQZ} and t_{GHQZ} parameters: Sampled only, not 100% tested.

Figure 21. Write AC Waveforms, Write Enable Controlled

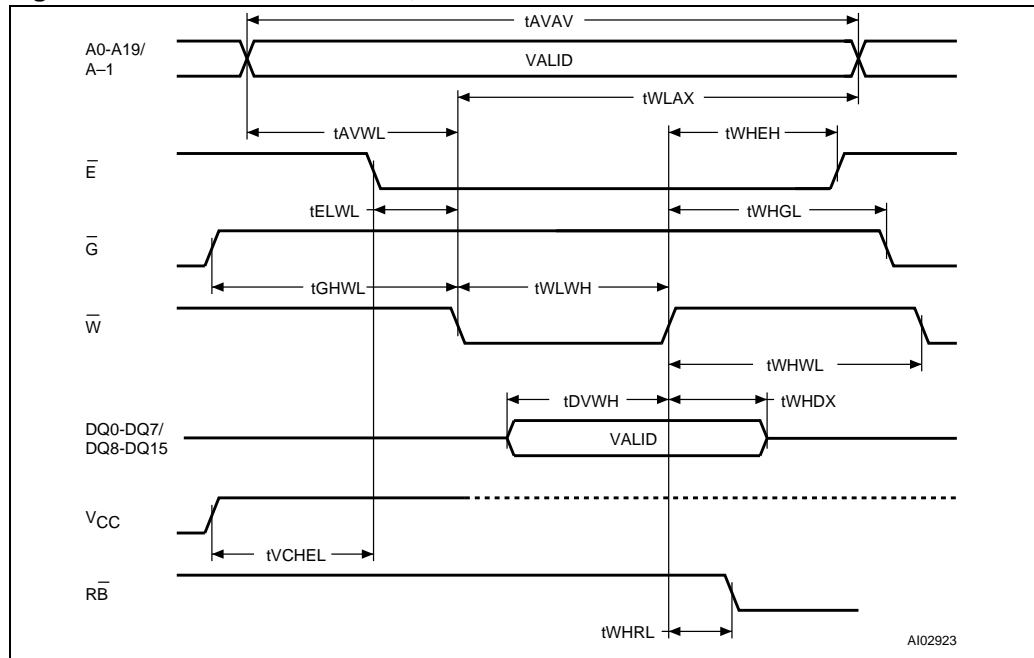

Table 16. Write AC Characteristics, Write Enable Controlled

Symbol	Alt	Parameter		M29F160F	Unit
				55/5A	
t_{AVAV}	t_{WC}	Address Valid to Next Address Valid	Min	55	ns
t_{ELWL}	t_{CS}	Chip Enable Low to Write Enable Low	Min	0	ns
t_{WLWH}	t_{WP}	Write Enable Low to Write Enable High	Min	30	ns
t_{DVWH}	t_{DS}	Input Valid to Write Enable High	Min	20	ns
t_{WHDX}	t_{DH}	Write Enable High to Input Transition	Min	0	ns
t_{WHEH}	t_{CH}	Write Enable High to Chip Enable High	Min	0	ns
t_{WHWL}	t_{WPH}	Write Enable High to Write Enable Low	Min	15	ns
t_{AVWL}	t_{AS}	Address Valid to Write Enable Low	Min	0	ns
t_{WLAX}	t_{AH}	Write Enable Low to Address Transition	Min	30	ns
t_{GHWL}		Output Enable High to Write Enable Low	Min	0	ns
t_{WHGL}	t_{OEH}	Write Enable High to Output Enable Low	Min	0	ns
t_{WHRL}	t_{BUSY}	Program/Erase Valid to \overline{RB} Low	Max	20	ns
t_{VCHL}	t_{VCS}	V_{CC} High to Chip Enable Low	Min	50	μ s

t_{WHRL} parameter: Sampled only, not 100% tested.

Figure 22. Write AC Waveforms, Chip Enable Controlled

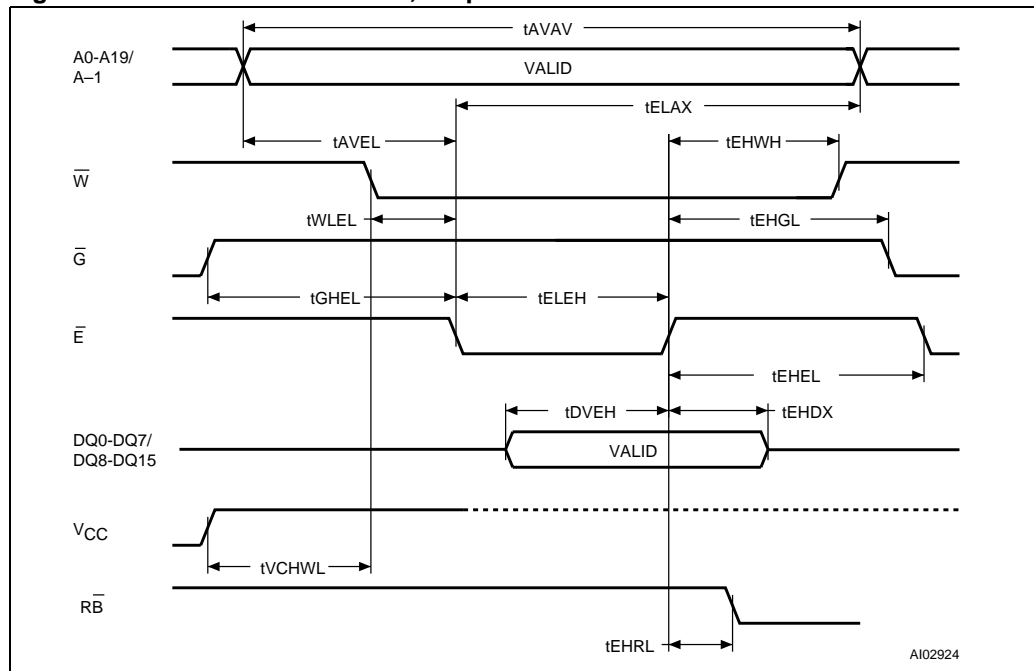

Table 17. Write AC Characteristics, Chip Enable Controlled

Symbol	Alt	Parameter		M29F160F	Unit
				55/5A	
t_{AVAV}	t_{WC}	Address Valid to Next Address Valid	Min	55	ns
t_{WLEL}	t_{WS}	Write Enable Low to Chip Enable Low	Min	0	ns
t_{ELEH}	t_{CP}	Chip Enable Low to Chip Enable High	Min	30	ns
t_{DVEH}	t_{DS}	Input Valid to Chip Enable High	Min	20	ns
t_{EHDX}	t_{DH}	Chip Enable High to Input Transition	Min	0	ns
t_{EHWH}	t_{WH}	Chip Enable High to Write Enable High	Min	0	ns
t_{EHEL}	t_{CPH}	Chip Enable High to Chip Enable Low	Min	15	ns
t_{AVEL}	t_{AS}	Address Valid to Chip Enable Low	Min	0	ns
t_{ELAX}	t_{AH}	Chip Enable Low to Address Transition	Min	30	ns
t_{GHGL}		Output Enable High Chip Enable Low	Min	0	ns
t_{EHGL}	t_{OEH}	Chip Enable High to Output Enable Low	Min	0	ns
t_{EHRL}	t_{BUSY}	Program/Erase Valid to \overline{RB} Low	Max	20	ns
t_{VCHWL}	t_{VCS}	V_{CC} High to Write Enable Low	Min	50	μ s

t_{EHRL} parameter: Sampled only, not 100% tested.

Figure 23. Reset/Block Temporary Unprotect AC Waveforms

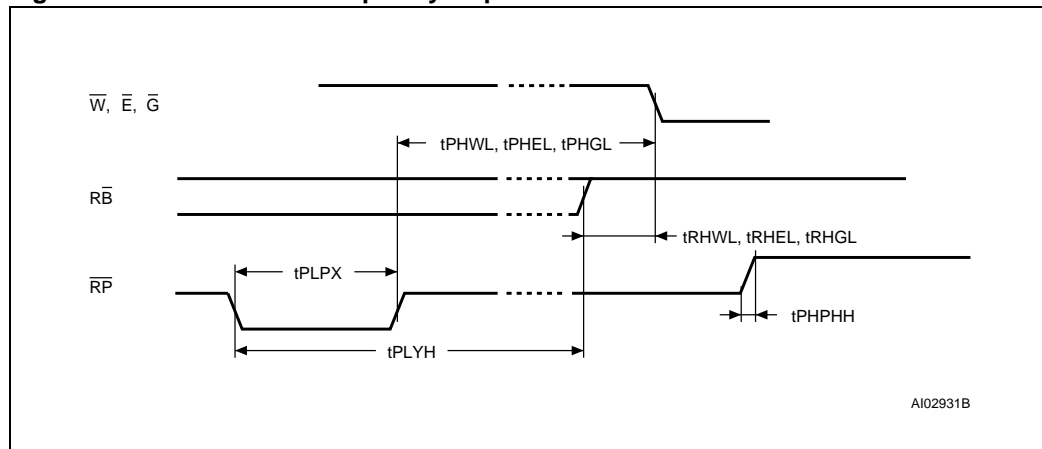

Table 18. Reset/Block Temporary Unprotect AC Characteristics

Symbol	Alt	Parameter		M29F160F	Unit
				55/5A	
t _{PHWL} t _{PHEL} t _{PHGL}	t _{RH}	\overline{RP} High to Write Enable Low, Chip Enable Low, Output Enable Low	Min	50	ns
t _{RHWL} t _{RHEL} t _{RHGL}	t _{RB}	\overline{RB} High to Write Enable Low, Chip Enable Low, Output Enable Low	Min	0	ns
t _{PLPX}	t _{RP}	\overline{RP} Pulse Width	Min	500	ns
t _{PLYH}	t _{READY}	\overline{RP} Low to Read Mode	Max	10	μs
t _{PHPHH}	t _{VIDR}	\overline{RP} Rise Time to V _{ID}	Min	500	ns

t_{PHWL} t_{PHGL} t_{RHWL} t_{RHEL} t_{RHGL} t_{PLYH} and t_{PHPHH} parameters: Sampled only, not 100% tested.

8 Package Mechanical

Figure 24. TSOP48 – 48 lead Plastic Thin Small Outline, 12 x 20mm, Package Outline, top view

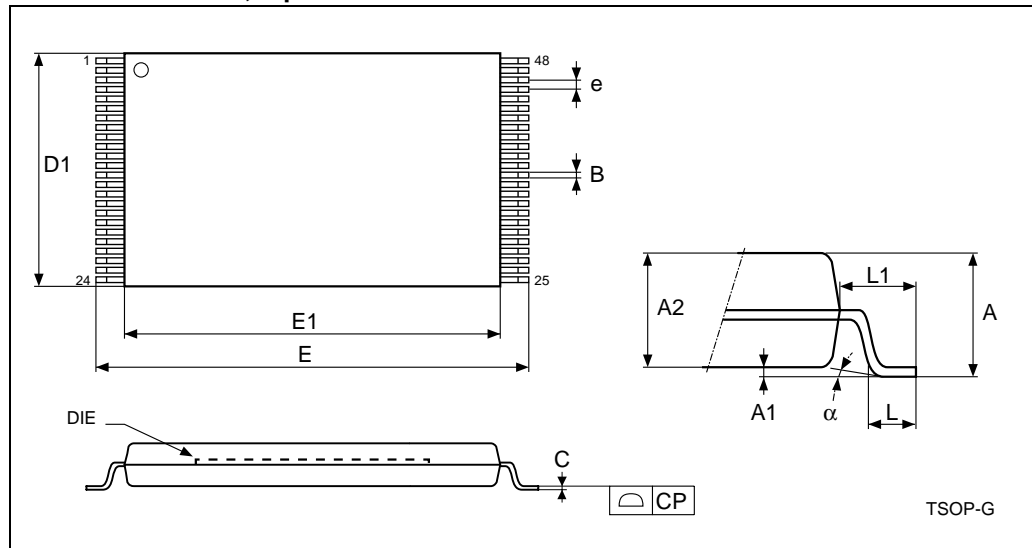

Drawing is not to scale.

Table 19. TSOP48 – 48 lead Plastic Thin Small Outline, 12 x 20mm, Package Mechanical Data

Symbol	millimeters		
	Typ	Min	Max
A			1.200
A1	0.100	0.050	0.150
A2	1.000	0.950	1.050
B	0.220	0.170	0.270
C		0.100	0.210
CP			0.080
D1	12.000	11.900	12.100
E	20.000	19.800	20.200
E1	18.400	18.300	18.500
e	0.500	–	–
L	0.600	0.500	0.700
L1	0.800		
a	3	0	5

Figure 25. SO44 – 44 lead plastic small outline, 500 mils body width, package outline

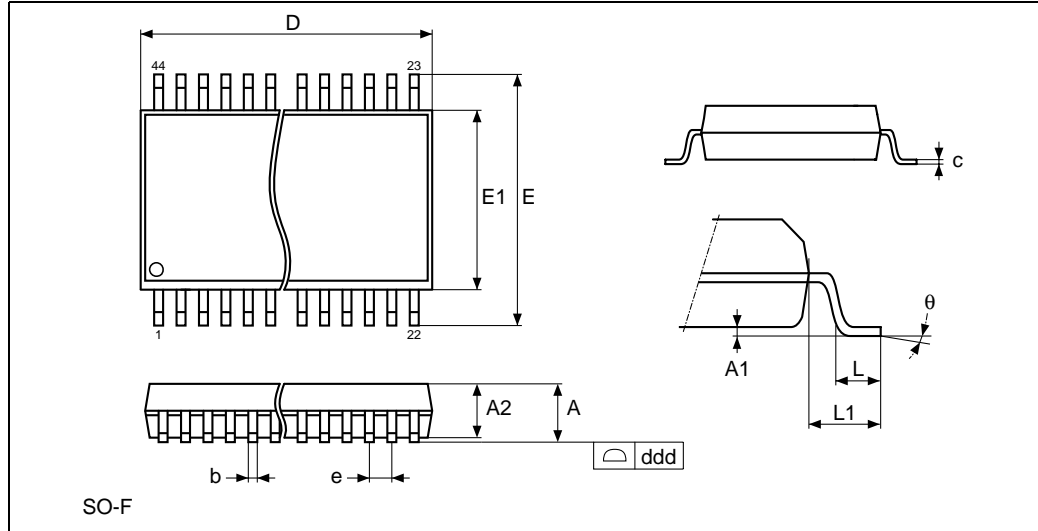

Table 20. SO44 - 44 lead Plastic Small Outline, 500 mils body width, package mechanical data

Symbol	millimeters		
	Typ	Min	Max
A			3.00
A1	0.10		
A2	2.69	2.56	2.79
b		0.35	0.50
c		0.18	0.28
D	28.50	28.37	28.63
ddd			0.10
E	16.03	15.77	16.28
E1	12.60	12.47	12.73
e	1.27	–	–
L	0.79		
L1	1.73		
θ			8°
N	44		

Figure 26. TFBGA48 6 x 8 mm - 6 x 8 ball array, 0.80 mm pitch, package outline

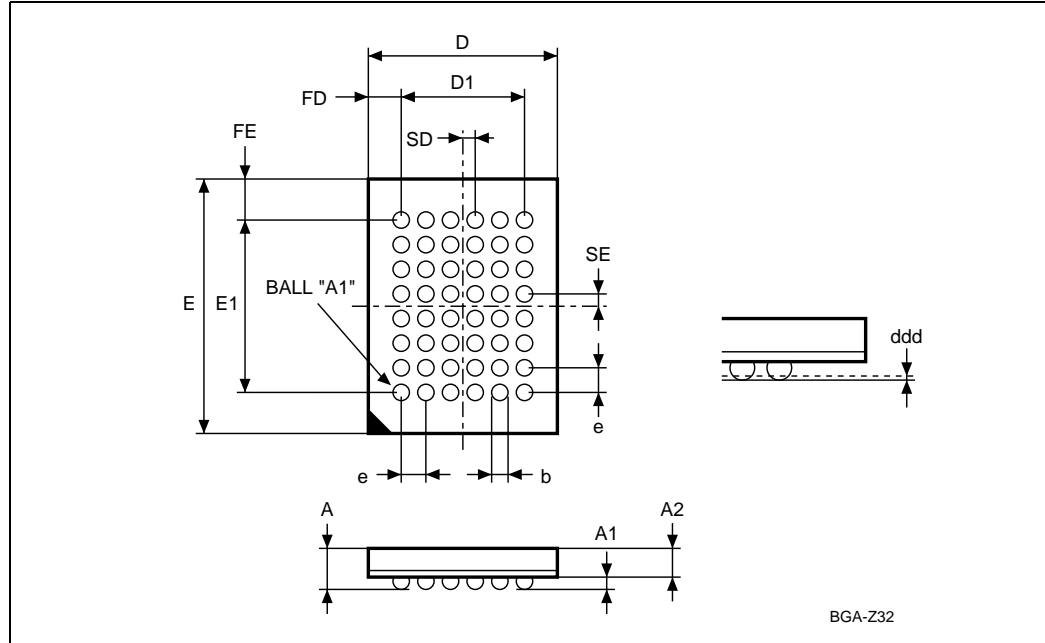

Table 21. TFBGA48 6 x 8 mm - 6 x 8 ball array, 0.80 mm pitch, package mechanical data

Symbol	millimeters			inches		
	Typ	Min	Max	Typ	Min	Max
A			1.200			0.0472
A1		0.260			0.0102	
A2			0.900			0.0354
b		0.350	0.450		0.0138	0.0177
D	6.000	5.900	6.100	0.2362	0.2323	0.2402
D1	4.000	–	–	0.1575	–	–
ddd			0.100			0.0039
E	8.000	7.900	8.100	0.3150	0.3110	0.3189
E1	5.600	–	–	0.2205	–	–
e	0.800	–	–	0.0315	–	–
FD	1.000	–	–	0.0394	–	–
FE	1.200	–	–	0.0472	–	–
SD	0.400	–	–	0.0157	–	–
SE	0.400	–	–	0.0157	–	–

9 Part Numbering

Table 22. Information scheme

Example:	M29F200F	T	5A	M	6	-	2
Device type							
M29F = 5 V							
Density							
200 = 2-Mbit							
400 = 4-Mbit							
800 = 8-Mbit							
160 = 16-Mbit (not available in SO44 package)							
Technology							
F = 110 nm							
Configuration							
T = Top Boot							
B = Bottom Boot							
Speed							
55 = 55 ns device speed in conjunction with temperature range = 3 denotes Auto Grade –40 to 125 °C parts							
5A = 55 ns Access time (Auto Grade) only in conjunction with the Grade 6 option							
Package							
M = SO 44.525 INCH CU							
N = TSOP-1 48 12 x 20 AL 4							
ZA ⁽¹⁾ = TFBGA48, 6 x 8 mm, 0.80 mm pitch							
Temperature range							
6 = –40 to 85 °C							
3 = –40 to 125 °C							
Packing option							
<blank> = standard packing (Tray)							
T = Tape & Reel 24 mm packing							
E = RoHS package, standard packing (Tray)							
F = RoHS package, Tape & Reel 24 mm packing							
Fab location							
2 = Numonyx Fab.2 (Singapore)							

1. This package is available only in the 8-Mbit, bottom boot configuration.

Devices are shipped from the factory with the memory content bits erased to '1'.

For a list of available options (Speed, Package, etc.) or for further information on any aspect of this device, please contact the Numonyx Sales Office nearest to you.

Appendix A Block Address Table

Table 23. Top Boot Block Addresses, M29F160FT

#	Size (KBytes)	Address Range (x8)	Address Range (x16)
34	16	1FC000h-1FFFFFFh	FE000h-FFFFFFh
33	8	1FA000h-1FBFFFh	FD000h-FDFFFh
32	8	1F8000h-1F9FFFh	FC000h-FCFFFh
31	32	1F0000h-1F7FFFh	F8000h-FBFFFh
30	64	1E0000h-1EFFFFh	F0000h-F7FFFh
29	64	1D0000h-1DFFFFh	E8000h-EFFFFh
28	64	1C0000h-1CFFFFh	E0000h-E7FFFh
27	64	1B0000h-1BFFFh	D8000h-DFFFFh
26	64	1A0000h-1AFFFFh	D0000h-D7FFFh
25	64	190000h-19FFFFh	C8000h-CFFFFh
24	64	180000h-18FFFFh	C0000h-C7FFFh
23	64	170000h-17FFFFh	B8000h-BFFFFh
22	64	160000h-16FFFFh	B0000h-B7FFFh
21	64	150000h-15FFFFh	A8000h-AFFFFh
20	64	140000h-14FFFFh	A0000h-A7FFFh
19	64	130000h-13FFFFh	98000h-9FFFFh
18	64	120000h-12FFFFh	90000h-97FFFh
17	64	110000h-11FFFFh	88000h-8FFFFh
16	64	100000h-10FFFFh	80000h-87FFFh
15	64	0F0000h-0FFFFFFh	78000h-7FFFFh
14	64	0E0000h-0EFFFFh	70000h-77FFFh
13	64	0D0000h-0DFFFFh	68000h-6FFFFh
12	64	0C0000h-0CFFFFh	60000h-67FFFh
11	64	0B0000h-0BFFFFh	58000h-5FFFFh
10	64	0A0000h-0AFFFFh	50000h-57FFFh
9	64	090000h-09FFFFh	48000h-4FFFFh
8	64	080000h-08FFFFh	40000h-47FFFh
7	64	070000h-07FFFFh	38000h-3FFFFh
6	64	060000h-06FFFFh	30000h-37FFFh
5	64	050000h-05FFFFh	28000h-2FFFFh
4	64	040000h-04FFFFh	20000h-27FFFh
3	64	030000h-03FFFFh	18000h-1FFFFh
2	64	020000h-02FFFFh	10000h-17FFFh
1	64	010000h-01FFFFh	08000h-0FFFFh
0	64	000000h-00FFFFh	00000h-07FFFh

Table 24. Bottom Boot Block Addresses, M29F160FB

#	Size (KBytes)	Address Range (x8)	Address Range (x16)
34	64	1F0000h-1FFFFFFh	F8000h-FFFFFFh
33	64	1E0000h-1EFFFFh	F0000h-F7FFFh
32	64	1D0000h-1DFFFFh	E8000h-EFFFFh
31	64	1C0000h-1CFFFFh	E0000h-E7FFFh
30	64	1B0000h-1BFFFFh	D8000h-DFFFFh
29	64	1A0000h-1AFFFFh	D0000h-D7FFFh
28	64	190000h-19FFFFh	C8000h-CFFFFh
27	64	180000h-18FFFFh	C0000h-C7FFFh
26	64	170000h-17FFFFh	B8000h-BFFFFh
25	64	160000h-16FFFFh	B0000h-B7FFFh
24	64	150000h-15FFFFh	A8000h-AFFFFh
23	64	140000h-14FFFFh	A0000h-A7FFFh
22	64	130000h-13FFFFh	98000h-9FFFFh
21	64	120000h-12FFFFh	90000h-97FFFh
20	64	110000h-11FFFFh	88000h-8FFFFh
19	64	100000h-10FFFFh	80000h-87FFFh
18	64	0F0000h-0FFFFFFh	78000h-7FFFFh
17	64	0E0000h-0EFFFFh	70000h-77FFFh
16	64	0D0000h-0DFFFFh	68000h-6FFFFh
15	64	0C0000h-0CFFFFh	60000h-67FFFh
14	64	0B0000h-0BFFFFh	58000h-5FFFFh
13	64	0A0000h-0AFFFFh	50000h-57FFFh
12	64	090000h-09FFFFh	48000h-4FFFFh
11	64	080000h-08FFFFh	40000h-47FFFh
10	64	070000h-07FFFFh	38000h-3FFFFh
9	64	060000h-06FFFFh	30000h-37FFFh
8	64	050000h-05FFFFh	28000h-2FFFFh
7	64	040000h-04FFFFh	20000h-27FFFh
6	64	030000h-03FFFFh	18000h-1FFFFh
5	64	020000h-02FFFFh	10000h-17FFFh
4	64	010000h-01FFFFh	08000h-0FFFFh
3	32	008000h-00FFFFh	04000h-07FFFh
2	8	006000h-007FFFh	03000h-03FFFh
1	8	004000h-005FFFh	02000h-02FFFh
0	16	000000h-003FFFh	00000h-01FFFh

Table 25. Top Boot Block Addresses, M29F800FT

#	Size (KBytes)	Address Range (x8)	Address Range (x16)
18	16	FC000h-FFFFFh	7E000h-7FFFFh
17	8	FA000h-FBFFFh	7D000h-7DFFFh
16	8	F8000h-F9FFFh	7C000h-7CFFFh
15	32	F0000h-F7FFFh	78000h-7BFFFh
14	64	E0000h-EFFFFh	70000h-77FFFh
13	64	D0000h-DFFFFh	68000h-6FFFFh
12	64	C0000h-CFFFFh	60000h-67FFFh
11	64	B0000h-BFFFFh	58000h-5FFFFh
10	64	A0000h-AFFFFh	50000h-57FFFh
9	64	90000h-9FFFFh	48000h-4FFFFh
8	64	80000h-8FFFFh	40000h-47FFFh
7	64	70000h-7FFFFh	38000h-3FFFFh
6	64	60000h-6FFFFh	30000h-37FFFh
5	64	50000h-5FFFFh	28000h-2FFFFh
4	64	40000h-4FFFFh	20000h-27FFFh
3	64	30000h-3FFFFh	18000h-1FFFFh
2	64	20000h-2FFFFh	10000h-17FFFh
1	64	10000h-1FFFFh	08000h-0FFFFh
0	64	00000h-0FFFFh	00000h-07FFFh

Table 26. Bottom Boot Block Addresses, M29F800FB

#	Size (KBytes)	Address Range (x8)	Address Range (x16)
18	64	F0000h-FFFFFh	78000h-7FFFFh
17	64	E0000h-EFFFFh	70000h-77FFFh
16	64	D0000h-DFFFFh	68000h-6FFFFh
15	64	C0000h-CFFFFh	60000h-67FFFh
14	64	B0000h-BFFFFh	58000h-5FFFFh
13	64	A0000h-AFFFFh	50000h-57FFFh
12	64	90000h-9FFFFh	48000h-4FFFFh
11	64	80000h-8FFFFh	40000h-47FFFh
10	64	70000h-7FFFFh	38000h-3FFFFh
9	64	60000h-6FFFFh	30000h-37FFFh
8	64	50000h-5FFFFh	28000h-2FFFFh
7	64	40000h-4FFFFh	20000h-27FFFh
6	64	30000h-3FFFFh	18000h-1FFFFh
5	64	20000h-2FFFFh	10000h-17FFFh
4	64	10000h-1FFFFh	08000h-0FFFFh
3	32	08000h-0FFFFh	04000h-07FFFh
2	8	06000h-07FFFh	03000h-03FFFh
1	8	04000h-05FFFh	02000h-02FFFh
0	16	00000h-03FFFh	00000h-01FFFh

Table 27. Top Boot Block Addresses, M29F400FT

#	Size (KBytes)	Address Range (x8)	Address Range (x16)
10	16	7C000h-7FFFFh	3E000h-3FFFFh
9	8	7A000h-7BFFFh	3D000h-3DFFFh
8	8	78000h-79FFFh	3C000h-3CFFFh
7	32	70000h-77FFFh	38000h-3BFFFh
6	64	60000h-6FFFFh	30000h-37FFFh
5	64	50000h-5FFFFh	28000h-2FFFFh
4	64	40000h-4FFFFh	20000h-27FFFh
3	64	30000h-3FFFFh	18000h-1FFFFh
2	64	20000h-2FFFFh	10000h-17FFFh
1	64	10000h-1FFFFh	08000h-0FFFFh
0	64	00000h-0FFFFh	00000h-07FFFh

Table 28. Bottom Boot Block Addresses, M29F400FB

#	Size (KBytes)	Address Range (x8)	Address Range (x16)
10	64	70000h-7FFFFh	38000h-3FFFFh
9	64	70000h-6FFFFh	30000h-37FFFh
8	64	50000h-5FFFFh	28000h-2FFFFh
7	64	40000h-4FFFFh	20000h-27FFFh
6	64	30000h-3FFFFh	18000h-1FFFFh
5	64	20000h-2FFFFh	10000h-17FFFh
4	64	10000h-1FFFFh	08000h-0FFFFh
3	32	08000h-0FFFFh	04000h-07FFFh
2	8	06000h-07FFFh	03000h-03FFFh
1	8	04000h-05FFFh	02000h-02FFFh
0	16	00000h-03FFFh	00000h-01FFFh

Table 29. Top Boot Block Addresses, M29F200FT

#	Size (KBytes)	Address Range (x8)	Address Range (x16)
6	16	3C000h-3FFFFh	1E000h-1FFFFh
5	8	3A000h-3BFFFh	1D000h-1DFFFh
4	8	38000h-39FFFh	1C000h-1CFFFh
3	32	30000h-37FFFh	18000h-1BFFFh
2	64	20000h-2FFFFh	10000h-17FFFh
1	64	10000h-1FFFFh	08000h-0FFFFh
0	64	00000h-0FFFFh	00000h-07FFFh

Table 30. Bottom Boot Block Addresses, M29F200FB

#	Size (KBytes)	Address Range (x8)	Address Range (x16)
6	64	30000h-3FFFFh	18000h-1FFFFh
5	64	20000h-2FFFFh	10000h-17FFFh
4	64	10000h-1FFFFh	08000h-0FFFFh
3	32	08000h-0FFFFh	04000h-07FFFh
2	8	06000h-07FFFh	03000h-03FFFh
1	8	04000h-05FFFh	02000h-02FFFh
0	16	10000h-1FFFFh	00000h-01FFFh

Appendix B Common Flash Interface (CFI)

The Common Flash Interface is a JEDEC approved, standardized data structure that can be read from the Flash memory device. It allows a system software to query the device to determine various electrical and timing parameters, density information and functions supported by the memory. The system can interface easily with the device, enabling the software to upgrade itself when necessary.

When the CFI Query Command is issued the device enters CFI Query mode and the data structure is read from the memory. Addresses used to retrieve the data are shown in the following tables:

- [Table 31.: Query Structure Overview](#),
- [Table 32.: CFI Query Identification String](#),
- [Table 33.: CFI Query System Interface Information](#),
- [Table 34.: Device Geometry Definition](#),
- [Table 35.: Primary Algorithm-Specific Extended Query Table](#)
- [Table 36.: Security Code Area](#)

The CFI data structure also contains a security area where a 64-bit unique security number is written (see [Table 36.: Security Code Area](#)). This area can be accessed only in Read mode by the final user. It is impossible to change the security number after it has been written by Numonyx. Issue a Read command to return to Read mode.

Table 31. Query Structure Overview

Address		Sub-section Name	Description
x16	x8		
10h	20h	CFI Query Identification String	Command set ID and algorithm data offset
1Bh	36h	System Interface Information	Device timing & voltage information
27h	4Eh	Device Geometry Definition	Flash device layout
40h	80h	Primary Algorithm-specific Extended Query table	Additional information specific to the Primary Algorithm (optional)
61h	C2h	Security Code Area	64 bit unique device number

Query data are always presented on the lowest order data outputs.

Table 32. CFI Query Identification String

Address		Data	Description	Value
x16	x8			
10h	20h	0051h	Query Unique ASCII String "QRY"	"Q"
11h	22h	0052h		"R"
12h	24h	0059h		"Y"
13h	26h	0002h	Primary Algorithm Command Set and Control Interface ID code 16 bit ID code defining a specific algorithm	AMD Compatible
14h	28h	0000h		
15h	2Ah	0040h	Address for Primary Algorithm extended Query table (see Table 34.)	P = 40h
16h	2Ch	0000h		

Address		Data	Description	Value
x16	x8			
17h	2Eh	0000h	Alternate Vendor Command Set and Control Interface ID Code second vendor - specified algorithm supported	NA
18h	30h	0000h		
19h	32h	0000h	Address for Alternate Algorithm extended Query table	NA
1Ah	34h	0000h		

Query data are always presented on the lowest order data outputs (DQ7-DQ0) only. DQ8-DQ15 are '0'.

Table 33. CFI Query System Interface Information

Address		Data	Description	Value
x16	x8			
1Bh	36h	0045h	V _{CC} Logic Supply Minimum Program/Erase voltage bit 7 to 4BCD value in volts bit 3 to 0BCD value in 100 mV	4.5 V
1Ch	38h	0055h	V _{CC} Logic Supply Maximum Program/Erase voltage bit 7 to 4BCD value in volts bit 3 to 0BCD value in 100 mV	5.5 V
1Dh	3Ah	0000h	V _{PP} [Programming] Supply Minimum Program/Erase voltage	NA
1Eh	3Ch	0000h	V _{PP} [Programming] Supply Maximum Program/Erase voltage	NA
1Fh	3Eh	0003h	Typical timeout per single Byte/Word program = 2 ⁿ μs	8 μs
20h	40h	0000h	Typical timeout for minimum size write buffer program = 2 ⁿ μs	NA
21h	42h	000Ah	Typical timeout per individual block erase = 2 ⁿ ms	1 s
22h	44h	0000h	Typical timeout for full chip erase = 2 ⁿ ms	NA
23h	46h	0004h	Maximum timeout for Byte/Word program = 2 ⁿ times typical	256 μs
24h	48h	0000h	Maximum timeout for write buffer program = 2 ⁿ times typical	NA
25h	4Ah	0003h	Maximum timeout per individual block erase = 2 ⁿ times typical	8 s
26h	4Ch	0000h	Maximum timeout for chip erase = 2 ⁿ times typical	NA

Table 34. Device Geometry Definition

Address		Data	Description	Value
x16	x8			
27h	4Eh	0015h	Device Size = 2 ⁿ in number of Bytes	2 MByte
		0014h		1 MByte
		0013h		512 KByte
		0012h		256 KByte
28h	50h	0002h	Flash Device Interface Code description	x8, x16 Async.
29h	52h	0000h		
2Ah	54h	0000h	Maximum number of Bytes in multi-Byte program or page = 2 ⁿ	NA
2Bh	56h	0000h		

Address		Data	Description	Value
x16	x8			
2Ch	58h	0004h	Number of Erase Block Regions within the device. It specifies the number of regions within the device containing contiguous Erase Blocks of the same size.	4
2Dh	5Ah	0000h	Region 1 Information	1
2Eh	5Ch	0000h	Number of identical size erase block = 0000h+1	
2Fh	5Eh	0040h	Region 1 Information	16 KByte
30h	60h	0000h	Block size in Region 1 = 0040h * 256 Byte	
31h	62h	0001h	Region 2 Information	2
32h	64h	0000h	Number of identical size erase block = 0001h+1	
33h	66h	0020h	Region 2 Information	8 KByte
34h	68h	0000h	Block size in Region 2 = 0020h * 256 Byte	
35h	6Ah	0000h	Region 3 Information	1
36h	6Ch	0000h	Number of identical size erase block = 0000h+1	
37h	6Eh	0080h	Region 3 Information	32 KByte
38h	70h	0000h	Block size in Region 3 = 0080h * 256 Byte	
39h	72h	001Eh	Region 4 Information (2 MByte)	31
3Ah	74h	0000h	Number of identical-size erase block = 001Eh+1	
39h	72h	000Eh	Region 4 Information (1 MByte)	15
3Ah	74h	0000h	Number of identical-size erase block = 000Eh+1	
39h	72h	0006h	Region 4 Information (512 KByte)	7
3Ah	74h	0000h	Number of identical-size erase block = 0006h+1	
39h	72h	0002h	Region 4 Information (256 KByte)	3
3Ah	74h	0000h	Number of identical-size erase block = 0002h+1	
3Bh	76h	0000h	Region 4 Information	64 KByte
3Ch	78h	0001h	Block size in Region 4 = 0100h * 256 Byte	

Table 35. Primary Algorithm-Specific Extended Query Table

Address		Data	Description	Value
x16	x8			
40h	80h	0050h	Primary Algorithm extended Query table unique ASCII string "PRI"	"P"
41h	82h	0052h		"R"
42h	84h	0049h		"I"
43h	86h	0031h	Major version number, ASCII	"1"
44h	88h	0030h	Minor version number, ASCII	"0"
45h	8Ah	0000h	Address Sensitive Unlock (bits 1 to 0) 00 = required, 01= not required Silicon Revision Number (bits 7 to 2)	Yes
46h	8Ch	0002h	Erase Suspend 00 = not supported, 01 = Read only, 02 = Read and Write	2

Address		Data	Description	Value
x16	x8			
47h	8Eh	0001h	Block Protection 00 = not supported, x = number of blocks in per group	1
48h	90h	0001h	Temporary Block Unprotect 00 = not supported, 01 = supported	Yes
49h	92h	0002h	Block Protect /Unprotect 02 = M29F200 04 = M29F400 08 = M29F800 10 = M29F160	2
		0004h		4
		0008h		8
		0160h		16
4Ah	94h	0000h	Simultaneous Operations, 00 = not supported	No
4Bh	96h	0000h	Burst Mode, 00 = not supported, 01 = supported	No
4Ch	98h	0000h	Page Mode, 00 = not supported, 01 = 4 page Word, 02 = 8 page Word	No

Table 36. Security Code Area

Address		Data	Description
x16	x8		
61h	C3h, C2h	XXXX	64 bit: unique device number
62h	C5h, C4h	XXXX	
63h	C7h, C6h	XXXX	
64h	C9h, C8h	XXXX	

Appendix C Block protection

Block protection can be used to prevent any operation from modifying the data stored in the Flash memory. Each Block can be protected individually. Once protected, Program and Erase operations on the block fail to change the data.

There are three techniques that can be used to control Block Protection, these are the Programmer technique, the In-System technique and Temporary Unprotection. Temporary Unprotection is controlled by the Reset/Block Temporary Unprotection pin, \overline{RP} ; this is described in the Signal Descriptions section.

Unlike the Command Interface of the Program/Erase Controller, the techniques for protecting and unprotecting blocks could change between different Flash memory suppliers.

C.1 Programmer Technique

The Programmer technique uses high (V_{ID}) voltage levels on some of the bus pins. These cannot be achieved using a standard microprocessor bus, therefore the technique is recommended only for use in Programming Equipment.

To protect a block follow the flowchart in [Figure 27.: Programmer Equipment Block Protect Flowchart](#). During the Block Protect algorithm, the A19-A12 Address Inputs indicate the address of the block to be protected. The block will be correctly protected only if A19-A12 remain valid and stable, and if Chip Enable is kept Low, V_{IL} , all along the Protect and Verify phases.

The Chip Unprotect algorithm is used to unprotect all the memory blocks at the same time. This algorithm can only be used if all of the blocks are protected first. To unprotect the chip follow [Figure 28.: Programmer Equipment Chip Unprotect Flowchart](#) and [Table 37.: Programmer Technique Bus Operations, BYTE = VIH or VIL](#), which give a summary of each operation.

The timing on these flowcharts is critical. Care should be taken to ensure that, where a pause is specified, it is followed as closely as possible. Do not abort the procedure before reaching the end. Chip Unprotect can take several seconds and a user message should be provided to show that the operation is progressing.

C.2 In-System Technique

The In-System technique requires a high voltage level on the Reset/Blocks Temporary Unprotect pin, \overline{RP} . This can be achieved without violating the maximum ratings of the components on the microprocessor bus, therefore this technique is suitable for use after the Flash memory has been fitted to the system.

To protect a block follow the flowchart in [Figure 29.: In-System Equipment Block Protect Flowchart](#). To unprotect the whole chip it is necessary to protect all of the blocks first, then all the blocks can be unprotected at the same time. To unprotect the chip follow [Figure 30.: In-System Equipment Chip Unprotect Flowchart](#).

The timing on these flowcharts is critical. Care should be taken to ensure that, where a pause is specified, it is followed as closely as possible. Do not allow the microprocessor to service interrupts that will upset the timing and do not abort the procedure before reaching

the end. Chip Unprotect can take several seconds and a user message should be provided to show that the operation is progressing.

Table 37. Programmer Technique Bus Operations, $\overline{\text{BYTE}} = V_{\text{IH}}$ or V_{IL}

Operation	$\overline{\text{E}}$	$\overline{\text{G}}$	$\overline{\text{W}}$	Address Inputs A0-A19	Data Inputs/Outputs DQ15A-1, DQ14-DQ0
Block Protect	V_{IL}	V_{ID}	V_{IL} Pulse	A9 = V_{ID} , A12-A19 Block Address Others = X	X
Chip Unprotect	V_{ID}	V_{ID}	V_{IL} Pulse	A9 = V_{ID} , A12 = V_{IH} , A15 = V_{IH} Others = X	X
Block Protection Verify	V_{IL}	V_{IL}	V_{IH}	A0 = V_{IL} , A1 = V_{IH} , A6 = V_{IL} , A9 = V_{ID} , A12-A19 Block Address Others = X	Pass = XX01h Retry = XX00h
Block Unprotection Verify	V_{IL}	V_{IL}	V_{IH}	A0 = V_{IL} , A1 = V_{IH} , A6 = V_{IH} , A9 = V_{ID} , A12-A19 Block Address Others = X	Retry = XX01h Pass = XX00h

Figure 27. Programmer Equipment Block Protect Flowchart

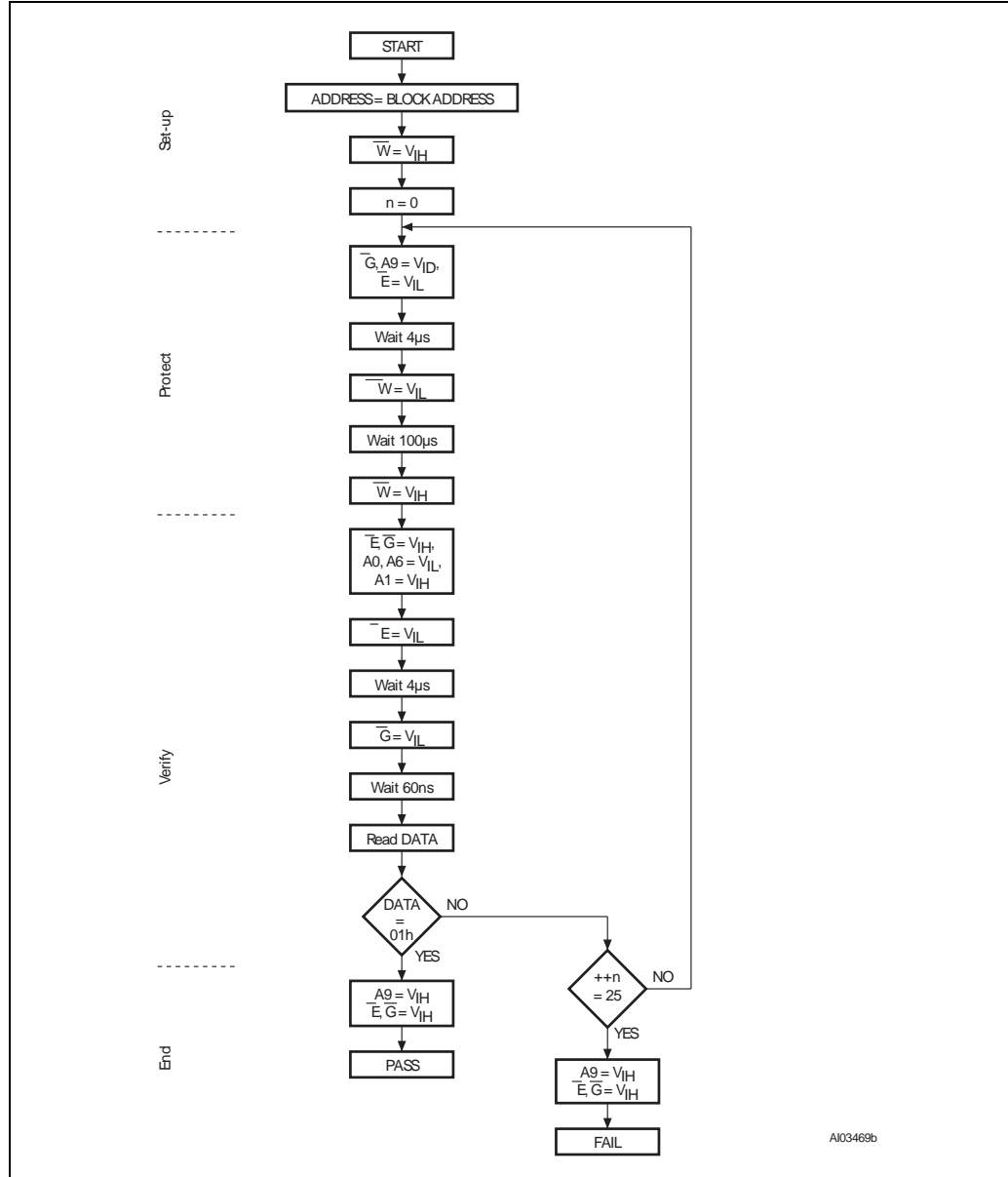

Address Inputs A19-A12 give the address of the block that is to be protected. It is imperative that they remain stable during the operation.

During the Protect and Verify phases of the algorithm, Chip Enable \bar{E} must be kept Low, V_{IL} .

Figure 28. Programmer Equipment Chip Unprotect Flowchart

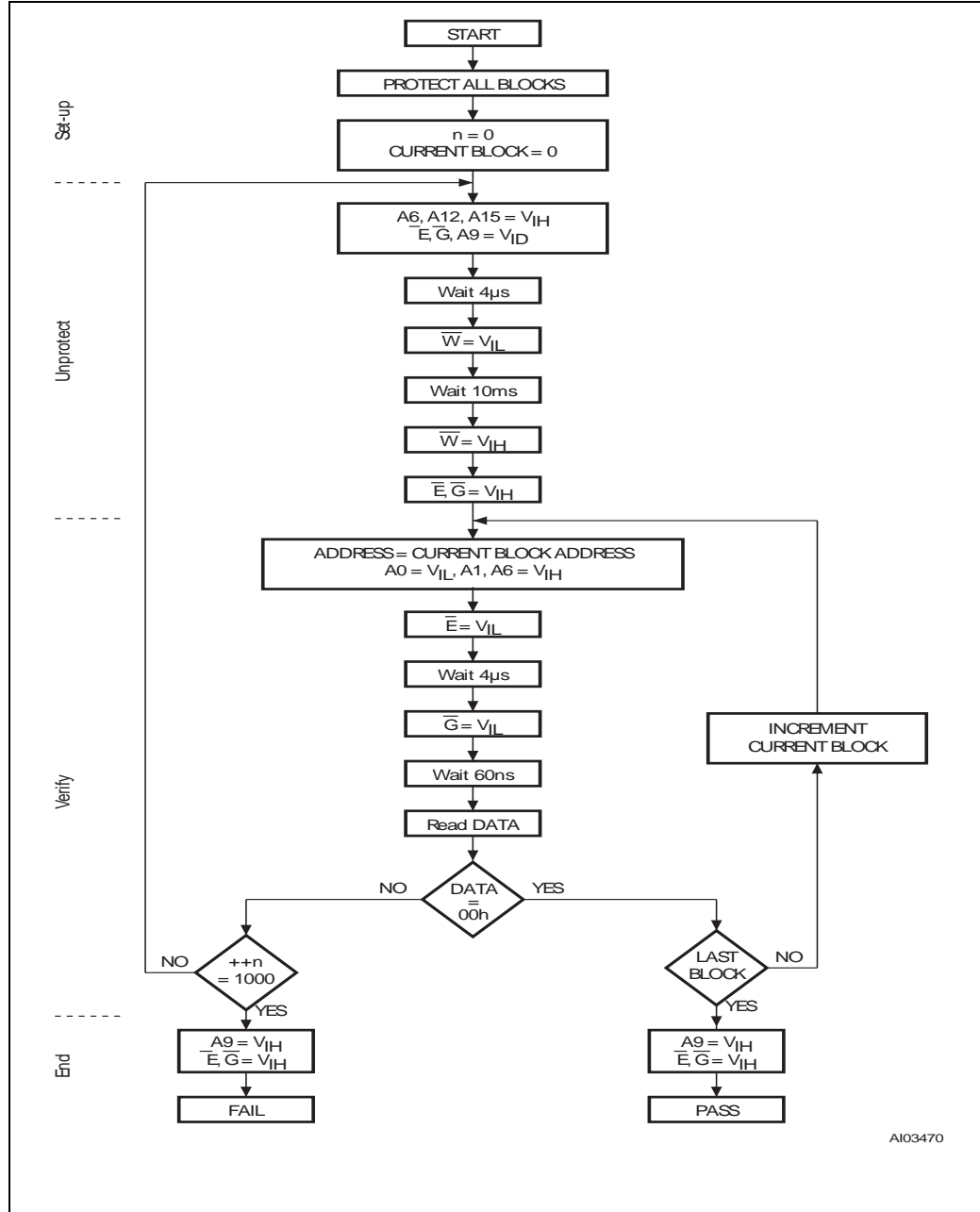

AI03470

Figure 29. In-System Equipment Block Protect Flowchart

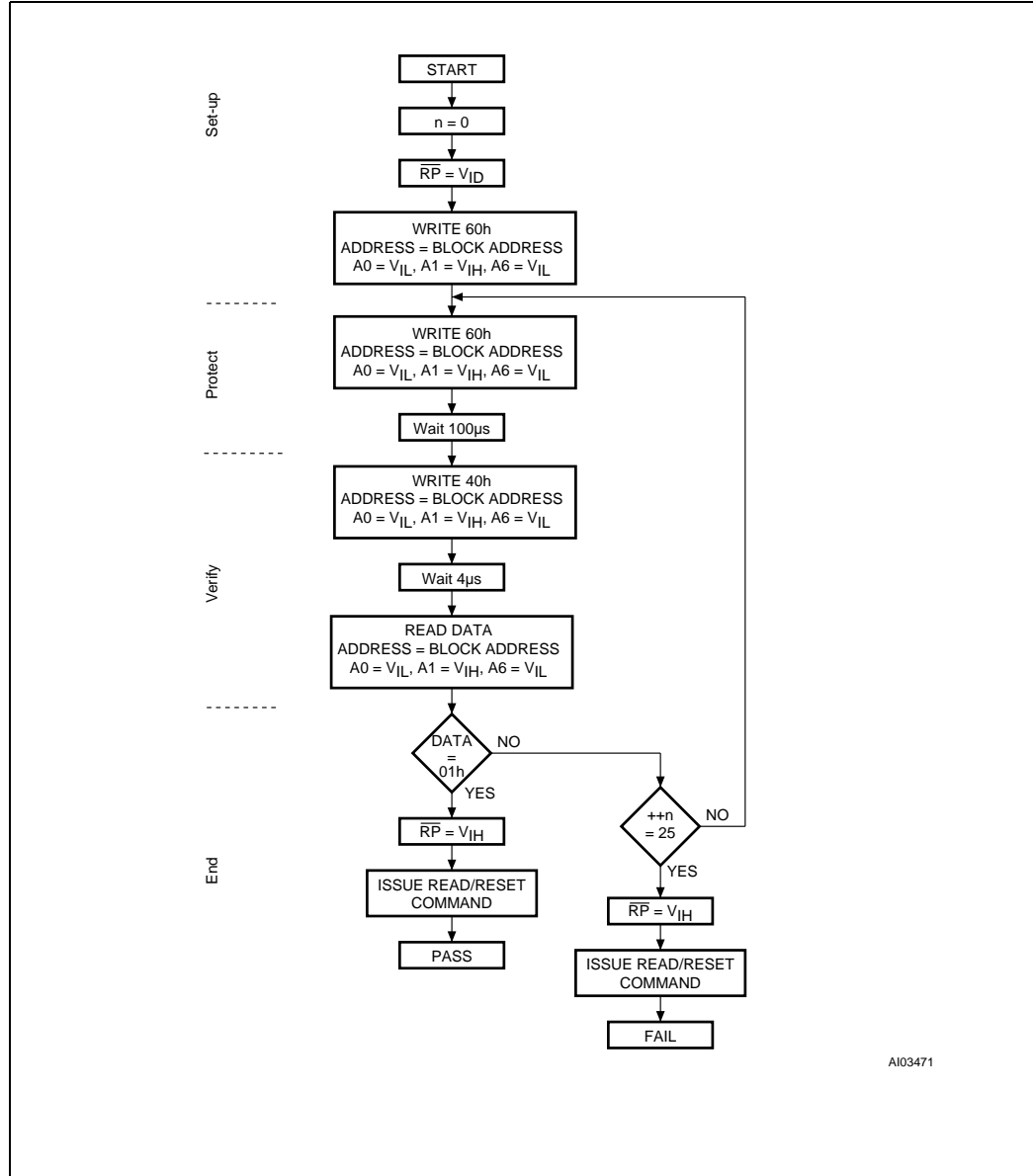

AI03471

Figure 30. In-System Equipment Chip Unprotect Flowchart

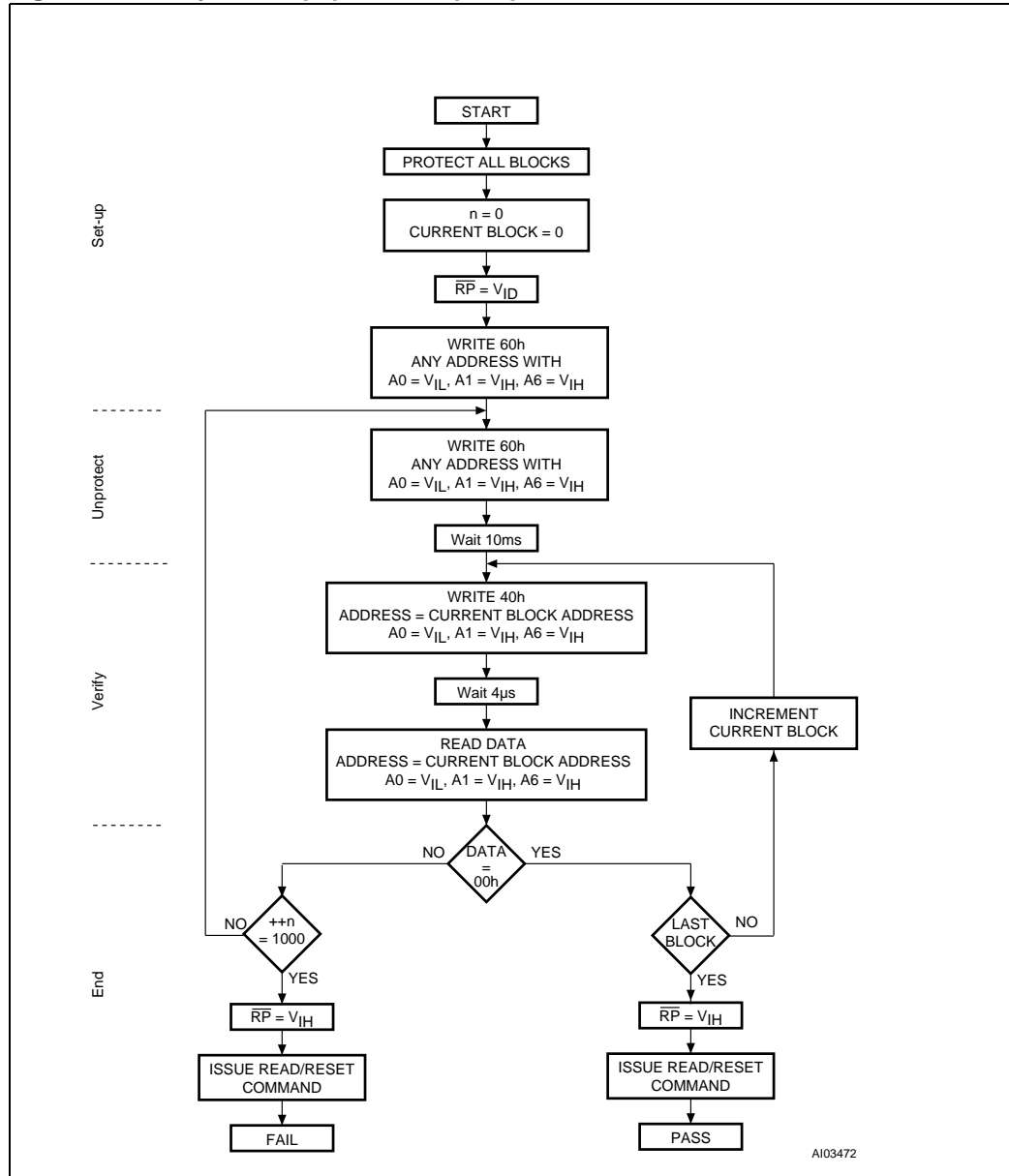

Appendix D Revision History

Table 38. Document Revision History

Date	Version	Revision Details
30-March-2009	1	Initial release.
1-April-2009	2	Corrected block diagram errors; Changed read manufacturer code and read device code to TBD. Added 55 ns option to speed option in Ordering Information table.
22-April-2009	3	Updated manufacturer code and device ID codes in the following locations: – cover page, – Table 2.: Bus Operations, BYTE = VIL – Table 3.: Bus Operations, BYTE = VIH – Table 34.: Device Geometry Definition – Table 35.: Primary Algorithm-Specific Extended Query Table Removed the following: – “preliminary” and delivery date from cover page; – 70 ns columns from all AC characteristics tables; – “inches” from package manufacturing tables.
27-May-2009	4	Removed the Note in the introduction to the Appendix B: Common Flash Interface (CFI) . Corrected the Description and Value information for Address 49h (x16) and 92h (x8) Table 35.: Primary Algorithm-Specific Extended Query Table ; Added additional speed and packing information to Ordering Information.
13-Aug-2009	5	TFBGA48 6 x 8 mm package added.
14-Oct-2009	6	Revised as follows: – Added / revised details in Order Information table. – Removed device code detail in 4.2: Auto Select Command – In Table 14.: DC Characteristics , changed ICC1 Max value from 10 to 20; changed ICC3 Max value from 20 to 30; changed VIL value from 0.5 °C to –0.5 °C – Removed “preliminary data” statement throughout the document. – In Figure 9.: TFBGA connections (top view through package) , changed VPP/WP to NC.
21-Oct-2009	7	Revised the following: In Table 14.: DC Characteristics , changed VIH from 0.8 V to 0.7 V.
8-Feb-2010	8	Minor text edits.
19-July-2010	9	Made minor text edits, and changed manufacturer code from 0020h to 0001h in Section 4.2: Auto Select Command on page 26 .

Devices are shipped from the factory with the memory content bits erased to '1'.

For a list of available options (Speed, Package, etc.) or for further information on any aspect of this device, please contact the Numonyx Sales Office nearest to you.

Please Read Carefully:

INFORMATION IN THIS DOCUMENT IS PROVIDED IN CONNECTION WITH NUMONYX™ PRODUCTS. NO LICENSE, EXPRESS OR IMPLIED, BY ESTOPPEL OR OTHERWISE, TO ANY INTELLECTUAL PROPERTY RIGHTS IS GRANTED BY THIS DOCUMENT. EXCEPT AS PROVIDED IN NUMONYX'S TERMS AND CONDITIONS OF SALE FOR SUCH PRODUCTS, NUMONYX ASSUMES NO LIABILITY WHATSOEVER, AND NUMONYX DISCLAIMS ANY EXPRESS OR IMPLIED WARRANTY, RELATING TO SALE AND/OR USE OF NUMONYX PRODUCTS INCLUDING LIABILITY OR WARRANTIES RELATING TO FITNESS FOR A PARTICULAR PURPOSE, MERCHANTABILITY, OR INFRINGEMENT OF ANY PATENT, COPYRIGHT OR OTHER INTELLECTUAL PROPERTY RIGHT.

Numonyx products are not intended for use in medical, life saving, life sustaining, critical control or safety systems, or in nuclear facility applications.

Numonyx may make changes to specifications and product descriptions at any time, without notice.

Numonyx, B.V. may have patents or pending patent applications, trademarks, copyrights, or other intellectual property rights that relate to the presented subject matter. The furnishing of documents and other materials and information does not provide any license, express or implied, by estoppel or otherwise, to any such patents, trademarks, copyrights, or other intellectual property rights.

Designers must not rely on the absence or characteristics of any features or instructions marked "reserved" or "undefined." Numonyx reserves these for future definition and shall have no responsibility whatsoever for conflicts or incompatibilities arising from future changes to them.

Contact your local Numonyx sales office or your distributor to obtain the latest specifications and before placing your product order.

Copies of documents which have an order number and are referenced in this document, or other Numonyx literature may be obtained by visiting Numonyx's website at <http://www.numonyx.com>.

Numonyx StrataFlash is a trademark or registered trademark of Numonyx or its subsidiaries in the United States and other countries.

*Other names and brands may be claimed as the property of others.

Copyright © 2010, Numonyx, B.V., All Rights Reserved.